

---

# Installation, Operation and Maintenance Manual

## Oil Fired Warm Air Furnaces

### WML-C AND MPL-B (Down-Flow or Horizontal Model)

### WMLV-C (Down-Flow or Horizontal Model with ECM)

ALL INSTALLATIONS MUST MEET ALL  
LOCAL, PROVINCIAL/STATE, AND  
FEDERAL CODES WHICH MAY DIF-  
FER FROM THIS MANUAL

**Olsen**  
*Heating & Cooling Products*

**Airco**  
*Heating & Cooling Products*

 **ecr**  
innovative living™

Read this complete manual before beginning installation. These instructions must be kept with the furnace for future reference.



---

## Table of Contents

INTRODUCTION.....	3
HEAT LOSS.....	3
LOCATION OF UNIT .....	3
AIR CONDITIONING.....	4
COMBUSTION AIR.....	5
CHIMNEY VENTING.....	5
DRAFT REGULATOR CONTROL.....	5
OPTIONAL SIDE WALL VENTING .....	7
OIL TANK .....	7
PIPING INSTALLATION.....	7
ELECTRICAL CONNECTIONS .....	7
FAN TIMER BOARD AND LIMIT CONTROL (FIG. 7)(PAGE 25).....	8
CIRCULATING AIR BLOWER (WML-C AND MPL-B).....	8
HUMIDIFIER .....	9
OIL BURNER.....	9
FURNACE INSTALLATION SET-UP .....	10
MAINTENANCE AND SERVICE .....	11
OPERATING INSTRUCTIONS (WML-C AND MPL-B) .....	12
ECM BLOWER MOTOR OPERATION.....	12
APPENDIX A- WML-C / WMLV-C AND MPL-B BURNER SET UP .....	13
A.1 OIL BURNER AIR ADJUSTMENT .....	15
A.2 BURNER ELECTRODES .....	15
A.3 START UP .....	15
A.4 SPECIAL INSTRUCTIONS FOR UNITS EQUIPPED WITH RIELLO BURNERS.....	15
TABLE A-6 DIRECT DRIVE BLOWER SET-UP .....	16
TABLE A-8 DIRECT DRIVE BLOWER CHARACTERISTICS .....	16
TABLE A-8A ECM BLOWER SET-UP .....	17
TABLE A-9 GENERAL DIMENSIONS (INCHES) .....	18
APPENDIX B: WIRING DIAGRAMS .....	19
OPERATION OF OIL BURNER.....	21
APPENDIX C OIL PRIMARY CONTROL DETAILED SEQUENCE OF OPERATION .....	22
TABLE C-1: ELECTRONIC FAN TIMER BOARD (EFT) DETAILED SEQUENCE OF OPERATION .....	25
OIL PRIMARY CONTROL LED  DIAGNOSTIC LIGHT.....	26
TABLE C-3: OIL PRIMARY CONTROL TROUBLESHOOTING.....	27
TABLE C4: SYSTEM AND GENERAL TROUBLESHOOTING .....	29
FINAL CHECK OUT .....	31
PARTS LISTING: COUNTERFLOW HORIZONTAL MODEL: WML-C AND WMLV-C .....	32
PARTS LISTING: COUNTERFLOW HORIZONTAL MODEL: MPL-B.....	35
HOMEOWNER’S REFERENCE TABLE .....	38

## **⚠ WARNING**

IMPROPER INSTALLATION MAY CREATE A CONDITION WHERE THE OPERATION OF THE PRODUCT COULD CAUSE PERSONAL INJURY OR PROPERTY DAMAGE.

IMPROPER INSTALLATION, ADJUSTMENT, ALTERATION, SERVICE OR MAINTENANCE CAN CAUSE INJURY OR PROPERTY DAMAGE. REFER TO THIS MANUAL FOR ASSISTANCE OR ADDITIONAL INFORMATION, CONSULT A QUALIFIED INSTALLER, SERVICE AGENCY OR THE FUEL SUPPLIER.

## **⚠ CAUTION**

THIS PRODUCT MUST BE INSTALLED IN STRICT COMPLIANCE WITH THESE INSTALLATION INSTRUCTIONS AND ANY APPLICABLE LOCAL, STATE, AND NATIONAL CODES INCLUDING BUT NOT LIMITED TO: BUILDING, ELECTRICAL AND MECHANICAL CODES.

## **⚠ WARNING**

The furnace area must not be used as a broom closet or for any other storage purposes, as a fire hazard may be created. Never store items such as the following on, near or in contact with the furnace:

1. Spray or aerosol cans, rags, brooms, dust mops, vacuum cleaners or other cleaning tools.
2. Soap powders, bleaches, waxes or other cleaning compounds; plastic items or containers, gasoline, kerosene, cigarette lighter fluid, dry cleaning fluids, or other volatile fluids.
3. Paint thinners or other painting materials and compounds.
4. Paper bags, boxes, or other paper or cardboard products.

Never operate the furnace with the blower door removed. To do so could result in serious personal injury and/or equipment damage.

## **⚠ WARNING**

**DO NOT USE GASOLINE, CRANK-CASE OIL, OR ANY OTHER OIL CONTAINING GASOLINE AS A FUEL FOR THIS FURNACE.**

### **INTRODUCTION**

Please read these instructions completely and carefully before installing and operating the furnace.

The furnace must be installed and set up by a qualified contractor.

Models WML-C and WMLV-C are oil fired forced air multi-positional furnaces, with an output capacity range of 58,000 BTU/Hr. to 85,600 BTU/Hr. The MPL-B is also an oil fired forced air multi-positional furnace with an output capacity range of 85,500 BTU/Hr. to 123,000 BTU/Hr. The WML-C / WMLV-C and MPL-B furnaces may be installed in the down-flow position, as well as both left and right horizontal positions.

All models are listed with the *Canadian Standards Association*, (CSA), and comply with the standards of both the United States and Canada for use with No. 1 (Stove) and No. 2 (Furnace) Oil.

In the United States, the installation of the furnace and related equipment shall be installed in accordance with the regulations of NFPA No. 31, *Standard for the Installation of Oil-Burning Equipment*, as well as in accordance with local codes.

In Canada, the installation of the furnace and related equipment shall be installed in accordance with the regulations of CAN/CSA - B139, *Installation Code For Oil-Burning Equipment*, as well as in accordance with local codes.

Regulations prescribed in the National Codes and Local Regulations take precedence over the general instructions provided with this installation manual. When in doubt, please consult your local authorities.

All models are shipped assembled and pre-wired. The furnace should be carefully inspected for damage when being unpacked.

### **HEAT LOSS**

To determine the correct furnace and firing rate for an application, it is necessary to calculate the maximum hourly heat loss of the building based on local design conditions. In new construction, the heat loss should be calculated on a room-by-room basis to enable proper

sizing of the trunk and branch ductwork. In retrofit applications, a building shell (overall) heat loss calculation may be used.

In the United States, Manual J, titled, "Load Calculation" published by the Air Conditioning Contractors of America, (ACCA), describes a suitable procedure for calculating the maximum hourly heat loss.

In Canada, the maximum hourly heat loss may be calculated in accordance with the procedures described in the manuals of the Heating, Refrigeration and Air Conditioning Institute (HRAI), or by other means prescribed, or approved by the local authority having jurisdiction.

### **LOCATION OF UNIT**

The furnace should be located such that the flue connection to the chimney is short, direct and consists of as few elbows as possible. When possible, the unit should be centralized with respect to the supply and return air ductwork. A central location minimizes the trunk duct sizing. All models may be installed on combustible floors. Do not install the furnace on carpet or tiled floors.

Minimum installation clearances are listed in Table 1.

**NOTE:** The recommended installation clearances do not necessarily take into consideration the clearances necessary to replace the air filter or perform other routine maintenance.

### **DOWN-FLOW INSTALLATION**

All WML-C / WMLV-C and MPL-B furnace models have been assembled for installation in the down-flow position. Maintain all clearances to combustibles as outlined in Table 1. *Suggestion*; as a measure to prevent fuel oil from accumulating in locations other than the fire pot, as could be the case in the event of nozzle drip, install the furnace with an approximate 2 degree slope from the oil burner casing towards the fire pot. Use shims made of noncombustible material.

## HORIZONTAL INSTALLATION

WML-C / WMLV-C and MPL-B furnace models are assembled and shipped ready for installation in the down-flow position. The furnace may be installed in either of the horizontal positions; warm air discharging left or warm air discharging right by following these steps:

1. Rotate the furnace 90° to the desired position.
2. Remove the three nut and washer sets fastening the oil burner assembly to the furnace. Rotate the oil burner assembly to be in the normal upright position.
3. Re-align the oil burner assembly to the combustion chamber (fire-pot), and then secure into place with the three nut and washer sets.

## NON-SUSPENDED INSTALLATION

Maintain clearances to combustibles as outlined in Table 1. Installation on a combustible floor requires a clearance of 1 inch. This can be done by using a non-combustible material such as one-inch thick channel iron or similar material. The furnace must be supported in such a way as to not allow twisting or sagging of the cabinet. Suggestion; as a measure to prevent fuel oil from accumulating in locations other than the fire pot, as could be the case in the event of nozzle drip, install the furnace with an approximate 2-degree slope from the oil burner casing towards the fire pot. Use shims made of

**Table 1: Clearance to Combustibles**

Furnace	WML-C / WMLV-C		MPL-B	
	Down flow	Horizontal	Down flow	Horizontal
Top	0 in.	3 in.	0 in.	3 in.
Bottom	1 in.	1 in.	1 in.	1 in.
S/A Plenum	1 in.	1 in.	1 in.	1 in.
Rear	1 in.	1 in.	1 in.	1 in.
Sides	1 in.	1 in.	1 in.	1 in.
Front	10 in. <sup>1</sup>	10 in. <sup>1</sup>	10 in. <sup>1</sup>	10 in. <sup>1</sup>
Flue Pipe	9 in. <sup>2</sup>	9 in. <sup>2</sup>	9 in. <sup>2</sup>	9 in. <sup>2</sup>
Enclosure	Closet	Closet	Closet	Closet

<sup>1</sup> 24 inches is required for servicing.  
<sup>2</sup> 18 inches required in the United States.

noncombustible material.

## SUSPENDED INSTALLATION

Refer to Figure 1. Maintain clearances to combustibles as outlined in Table 1. The furnace may be suspended by field fabricating a cradle of angle iron and threaded rod. Secure the furnace with 2 inch minimum slotted angle or equivalent, as shown in Figure 1. The furnace must be supported in such a way as to not allow twisting or sagging of the cabinet. Position the supports so as to not interfere with accessing the burner and blower compartments. Suggestion; as a measure to prevent fuel oil from accumulating in locations other than the fire pot, as could be the case in the event of nozzle

drip, install the furnace with an approximate 2 degree slope from the oil burner casing towards the fire pot.

## AIR CONDITIONING

If the furnace is used in conjunction with air conditioning, the furnace shall be installed in parallel with or upstream from the evaporator coil to avoid condensation in the heat exchanger. In a parallel installation, the dampers or air controlling means must prevent chilled air from entering the furnace. If the dampers are manually operated, there must be a means of control to prevent the operation of either system unless the dampers are in the full heat or full cool position. The air heated by the furnace shall not pass

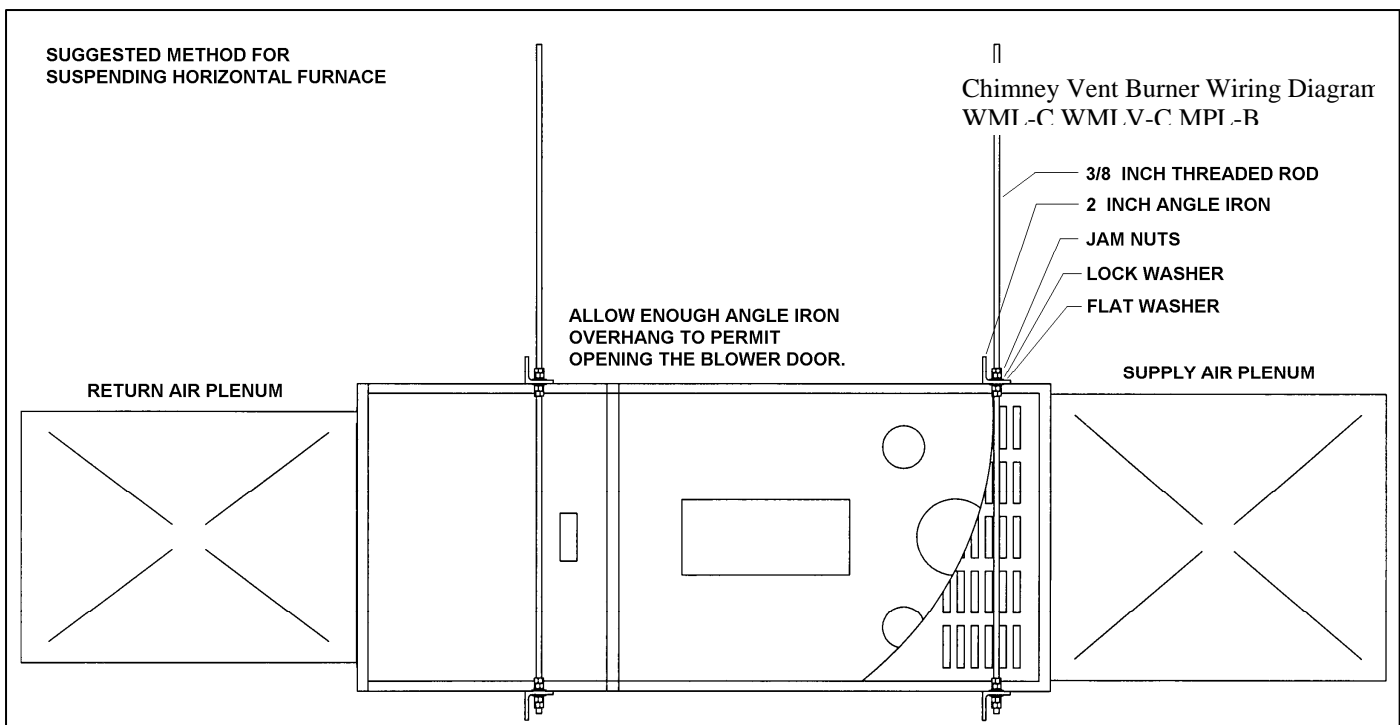

through a refrigeration unit unless the unit is specifically approved for such service.

Generally, a six-inch clearance between the air conditioning evaporator coil and the heat exchanger will provide adequate airflow through the evaporator coil.

The blower speed must be checked and adjusted to compensate for the pressure drop caused by the evaporator coil. Refer to Appendix B for recommended wiring and electrical connections of the air conditioning controls.

### COMBUSTION AIR

When a furnace is installed in the full basement of a typical frame or brick house, infiltration is normally adequate to provide air for combustion and draft operation. If the furnace is installed in a closet or utility room, two (2) ventilation openings must be provided connecting to a well ventilated space (full basement, living room or other room opening thereto, but not a bedroom or bathroom). One opening shall be located 6" from the top and bottom of the enclosure at the front of the furnace. For furnaces located in buildings of unusually tight construction, such as those with high quality weather stripping, caulking, windows and doors, or storm sashed windows, or where basement windows are well sealed, a permanent opening communicating with a well ventilated attic or with the outdoors shall be provided, using a duct if necessary. Size all of the openings and associated ductwork by the standards provided in the latest Oil Installation Code editions; NFPA 31 in the United States, CAN/CSA B139 in Canada. Take all fuel burning appliances in the area into consideration when calculating combustion and ventilation air requirements.

The Model CAS-2B-90E Furnace Boot manufactured by Field Controls, Inc. may be used with the furnace to obtain combustion air from outdoors. Use of this device does not alter the need for ventilation air; however, it does provide a good source of combustion air and is connected to the oil burner.

### CHIMNEY VENTING

The chimney must be sized correctly and be in good repair. If the chimney is oversized, there is a high risk of the flue gases condensing resulting in damage to the chimney and other venting parts. This problem may be corrected by the use of an appropriately sized chimney liner.

If the chimney serves the WML-C and WMLV-C furnaces only, the vent should be sized at 5-inch minimum. The MPL-B should be 6-inch minimum. The data provided in Table 3 is based on dedicated venting. If the furnace is to be co-vented with other appliances, refer to NFPA 211, *Standard for Chimneys, Fireplaces, Vents, and Solid Fuel-Burning Appliances*, NFPA 31, *Standard for the Installation of Oil-Burning Equipment* or CAN/CSA B139, *Installation Code For Oil-Burning Equipment* for correct sizing information.

**NOTE: This furnace is approved for use with L-Vent.**

**NOTE: Maximum temperature for L-Vent is 575°F (300°C).**

**IMPORTANT:** The chimney must be capable of providing sufficient draft at all times for the safe removal of the products of combustion.

The chimney should be tested under "winter" conditions; doors and windows closed, all other fossil fuel burning appliances on, clothes dryer on, bathroom fans on, etc. If the chimney cannot overcome the competition for air, it will be necessary to access the reason for it, and take corrective action. If the chimney is found to be sized correctly and in good repair, it will probably be necessary to re-evaluate the availability of combustion and ventilation air, and take corrective action.

The flue pipe should be as short as possible with horizontal pipes sloping upward toward the chimney at a rate of one-quarter inch to the foot. The flue pipe should not be smaller in cross sectional area than the flue collar on the furnace. The flue pipe should connect to the chimney such that the flue pipe extends into, and terminates flush with the inside surface of the chimney liner. Seal the joint between the pipe and the lining. The chimney outlet should be at least two feet above the highest point of a peaked roof. All unused chimney openings should be closed. Chimneys must conform to local, provincial or state codes, or in the absence of local regulations, to the requirements of the National Building Code.

See Figure 2 and Table 2 for common chimney problems and their remedies.

### CAUTION

THE FURNACE MUST BE CONNECTED TO A FLUE HAVING SUFFICIENT DRAFT AT ALL TIMES TO ENSURE SAFE AND PROPER OPERATION OF THE APPLIANCE.

The flue pipe must not be routed through concealed space, because it must be visually checked for signs of deterioration during the annual inspection and servicing. The flue pipe must not pass through any floor or ceiling, but may pass through a wall where suitable fire protection provisions have been installed. In the United States, refer to the latest edition of NFPA 31 for regulations governing the installation of oil burning equipment. In Canada, refer to the latest edition of CAN/CSA B139 for rules governing the installation of oil burning equipment.

**NOTE: THE RECOMMENDED FLUE DRAFT PRESSURE IS -0.02 IN. W.C. (AS MEASURED UPSTREAM OF THE BAROMETRIC DRAFT REGULATOR). SHOWN IN FIGURE 1.**

### DRAFT REGULATOR CONTROL

This device is used in conjunction with conventional chimney venting. This control (or draft regulator) automatically maintains a constant negative pressure in the furnace to obtain maximum efficiency. It ensures that proper pressures are not exceeded. If the chimney does not develop sufficient draft, the draft control cannot function properly. The draft regulator, must be installed within the same room or enclosure as the furnace, and should not interfere with the combustion air supplied to the burner. The control should be located a minimum of 3 flue pipe diameters from the furnace breeching and installed in accordance to the instructions supplied with the regulator.

**Fig. 2: Common Chimney Problems**

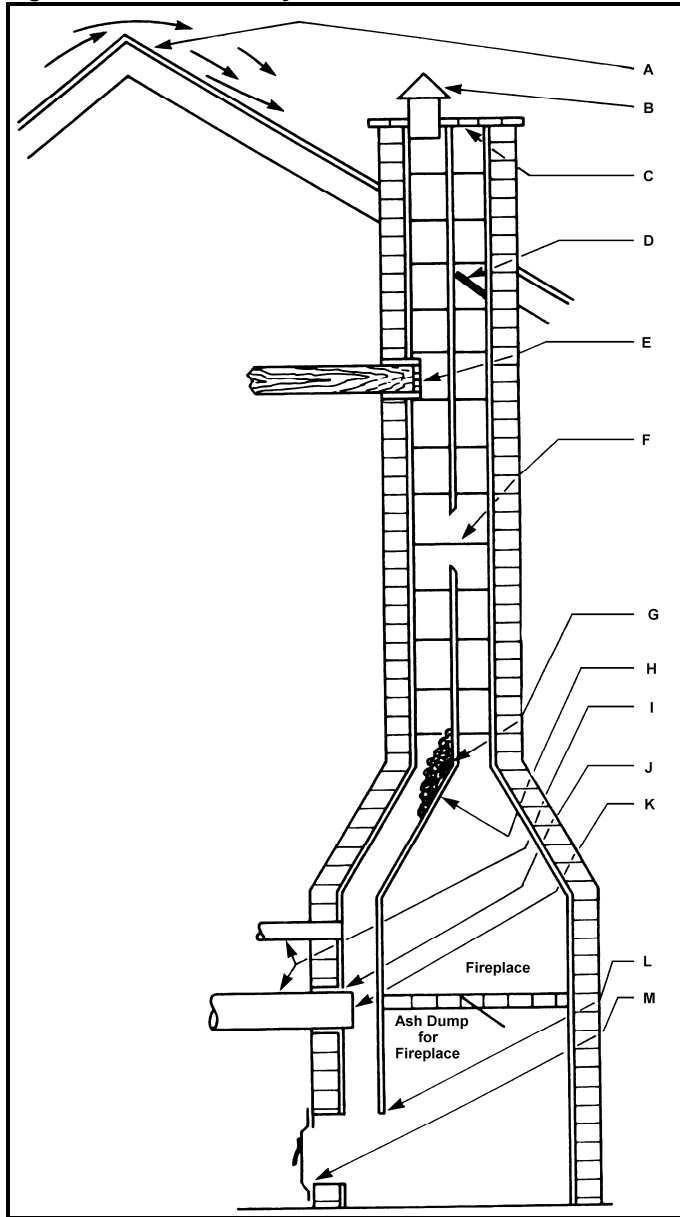

**Table 2: Common Chimney Problems**

Refer to Figure 2			
Key	Trouble	Diagnostic	Remedy
A	Top of chimney lower than surrounding objects	Observation	Extend chimney above all surrounding objects within 30 feet.
B	Chimney Cap or ventilator.	Observation	Remove
C	Coping restricts opening.	Observation	Make opening as large as inside of chimney.

D	Obstruction in chimney	Can be found by light and mirror reflecting conditions in chimney.	Use weight to break and dislodge.
E	Joist protruding into chimney.	Lowering a light on an extension cord.	Must be handled by competent masonry contractor.
F	Break in chimney lining.	Smoke test - build smudge fire blocking off other opening, watching for smoke to escape.	Must be handled by competent masonry contractor.
G	Collection of soot at narrow space in flue opening.	Lower light on extension cord.	Clean out with weighted brush or bag of loose gravel on end of line.
H	Offset	Lower light on extension cord.	Change to straight or to long offset.
I	Two or more openings to the same chimney.	Found by inspection from basement.	The least important opening must be closed, using some other chimney flue.
J	Loose-seated pipe in flue opening.	Smoke test.	Leaks should be eliminated by cementing all pipe openings.
K	Smoke pipe extends into chimney.	Measurement of pipe from within or observation of pipe by means of a lowered light.	Length of pipe must be reduced to allow end of pipe to be flush with inside of tile.
L	Failure to extend the length of flue partition to the floor.	By inspection or smoke test.	Extend partition to floor level.
M	Loose-fitted clean-out door.	Smoke test.	Close all leaks with cement.

## OPTIONAL SIDE WALL VENTING

Certain WML-C / WMLV-C and MPL-B furnace models are manufactured to be installed as sidewall vented units. Please refer to Direct Venting Instructions, P/N 240006979 included with the Vent Kit for details. Sidewall Venting (*Direct Venting*) requires the use of specific oil burners; the Beckett AFII, or the Riello 40BF. Please refer to Appendix A, Tables A2, and A4.

Note: Sidewall venting requires special attention to combustion air supply. There is no natural draft in the venting system between furnace cycles; therefore, if the indoor pressure is negative relative to the outdoors, the vent terminal becomes a point of infiltration. This could lead to oil odour control problems. This problem is rectified by the use of ducted outdoor air for combustion (semi-sealed combustion), using the Beckett AFII or Riello 40BF oil burner. See Direct Vent Instructions supplied with the Vent Kits.

**Table 3: Minimum Chimney Base Temperatures (°F)**

Nozzle	Chimney Height (ft.)			
	11	20	28	36
Chimney Thermal Resistance < R6				
0.50	300	400	535	725
0.65	275	340	430	535
0.70	270	330	405	505
0.75	260	320	380	475
0.85	250	300	355	430
1.00	225	300	365	430
Nozzle	Chimney Height (ft.)			
	11	20	28	36
Chimney Thermal Resistance > R6				
0.50	185	200	220	250
0.65	175	185	205	220
0.70	175	185	195	215
0.75	175	185	195	210
0.85	165	185	195	205
1.00	165	185	195	205

< - less than, > - greater than

## OIL TANK

Oil storage tanks must be selected and installed in compliance with applicable codes; in the United States, NFPA 31, *Standard for the Installation of Oil Burning Equipment*, Chapter 2. and in Canada, CAN/CSA-B139, *Installation Code for Oil Burning Equipment*, Section 6. Observe all local codes and by-laws.

In general, the oil tank must be properly supported and remain stable in both empty and full condition. The oil tank must be fitted with vent and supply pipes to the outdoors. Refer to the above-mentioned codes for sizing. The vent pipe must be no less than 1¼ inches I.P.S., and terminate with an appropriate vent cap in a location where it will not be blocked. The fill pipe must be no less than 2 inches I.P.S., and terminate with an appropriate cap in a location where debris will not enter the fill pipe during oil delivery.

If located indoors, the tank should normally be in the lowest level, (cellar, basement, etc.). It must be equipped with a shut-off valve at the tank outlet used for the oil supply. The oil tank must be located as to not block the furnace / room exit pathway. Observe all clearances specified in the above-mentioned codes.

## PIPING INSTALLATION

In the United States, NFPA 31, Standard for the Installation of Oil Burning Equipment, Chapter 2.

In Canada, the entire fuel system should be installed in accordance with the requirements of CAN/CSA B139, and local regulations. Use only approved fuel oil tanks piping, fittings and oil filters.

Ensure that all fittings used in a copper oil line system are high quality flare fittings. Do not use compression fittings.

Do not use Teflon tape on any fittings.

Pressurized or gravity feed installations must not exceed 3 PSIG. Pressures greater than 10 PSIG may cause damage to the shaft seal. If the height of the oil stored in a tank above the oil burner exceeds 11½ feet, it may be necessary to use a pressure-regulating device approved for this purpose.

The furnace may be installed with a one-pipe system with gravity feed or lift. The maximum allowable lift on a single line system is 8 feet. Lift should be measured from the bottom (outlet) of the tank, to the inlet of the burner. Sizing a single line system is complex because of the difficulty estimating the pressure drop through each fitting, bend and component in the line. In general, keep single line systems short as possible. The following chart shows the allowable line lengths (horizontal + vertical) for single and two-line oil piping systems. All distances are in feet.

**Table 4: Oil Lines**

Lift (Feet)	Copper Tubing Oil Line Length (Feet)			
	Single-Pipe OD		Two-Pipe OD	
	3/8"	1/2"	3/8"	1/2"
0	53	100	68	100
1	49	100	65	100
2	45	100	63	100
3	41	100	60	100
4	37	100	58	100
5	33	100	55	100
6	29	100	53	100
7	25	99	50	100
8	21	83	48	100
9	17	68	45	100
10	13	52	42	100
12	---	---	37	100
14	---	---	32	100
16	---	---	27	100
18	---	---	22	88

In retrofit applications, where an existing oil line system is in place, a vacuum check will help determine the efficacy of the existing oil line system. The vacuum in a system should not exceed 6" Hg. for a single pipe system, nor 12" Hg. for a two-pipe system.

**NOTE:** The oil burner requires the use of a bypass plug when converting from single-pipe to two-pipe oil piping systems. See burner manufacturer's instructions.

All fuel systems should include an oil filter between the fuel oil storage tank and the oil burner. For best results, install the oil filter as close to the burner as possible. When using an indoor oil tank, the oil filter may be installed at the tank downstream from the shut-off valve. If firing the furnace under the 0.65 GPH rate, a 7 to 10 micron line filter should be installed as close to the oil burner as possible.

## ELECTRICAL CONNECTIONS

The furnace is listed by the Canadian Standards Association (CSA). It is factory wired and requires minimal field wiring. In the United States, the wiring must be in accordance with the National Fire Protection Association NFPA-70, National Electrical Code, and with local codes and regulations. In Canada, all field wiring should conform to CAN/CSA C22.1 Canadian Electrical Code, Part 1, and by local codes, where they prevail.

The furnace should be wired to a separate and dedicated circuit in the main

electrical panel; however, accessory equipment such as electronic air cleaners and humidifiers may be included on the furnace circuit. Although a suitably located circuit breaker can be used as a service switch, a separate service switch is advisable. The service switch is necessary if reaching the circuit breaker involves becoming close to the furnace, or if the furnace is located between the circuit breaker and the means of entry to the furnace room. The furnace switch (service switch) should be clearly marked, installed in an easily accessible area between the furnace and furnace room entry, and be located in such a manner to reduce the likelihood that it would be mistaken as a light switch or similar device.

The power requirements for all models: 120 VAC, 1 ∅, 60 Hz., 12A.

Accessories requiring 120 VAC power sources such as electronic air cleaners and humidifier transformers may be powered from the fan timer board where provisions have been made for connections, but should have their own controls. Do not use the direct drive motor connections as a power source, since there is a high risk of damaging the accessories by exposure to high voltage from the auto-generating windings of the direct drive motor.

Thermostat wiring connections and air conditioning contactor low voltage connections are shown in the wiring diagrams. Some micro-electronic thermostats require additional controls and wiring. Refer to the thermostat manufacturer's instructions.

The thermostat should be located approximately 5 feet above the floor, on an inside wall where there is good natural air circulation, and where the thermostat will be exposed to average room temperatures. Avoid locations where the thermostat will be exposed to cold drafts, heat from nearby lamps and appliances, exposure to sunlight, heat from inside wall stacks, etc.

Normal heat anticipator setting: 0.1 A. For more precise adjustment, the heat anticipator may be adjusted to the amperage draw of the heating control circuit as measured between the "R" and "W" terminals of the thermostat. To reduce the risk of damaging the heat anticipator, do not measure circuit without first removing one of the two wires first. To determine the heating circuit amperage draw:

1. Disconnect one of the "R" or "W" wires from the thermostat terminal.
2. Connect an ammeter between the wire and the thermostat terminal to which it was attached.
3. Note the amperage reading when the heating contacts are closed. (System switch must be on "HEAT" if so equipped.)
4. Re-connect the thermostat wire. If the thermostat is serving a combination heating and air conditioning system, pay particular attention to polarity.
5. When the thermostat is reconnected and re-plumbed, adjust the heat anticipator setting to match the observed amperage reading.

#### FAN TIMER BOARD AND LIMIT CONTROL (FIG. 7)(page 25)

The Electronic Fan Timer integrates control of all burner and circulator fan operations. This control is the central wiring point for most of the electrical components in the furnace. The **United Technologies 1158-120 (WML-C and MPL-B)** has an adjustable fan on time that is set by selecting the dipswitch combination displayed in Table 5. This fan on delay can be set at 30, 60, 90 or 120 seconds. This provides a delay between the burner ignition and blower start-up to eliminate excessive flow of cold air when the blower comes on. The **United Technologies 1158-120 (WML-C and MPL-B)** has an adjustable fan off time of 2, 3, 4 or 6 minutes displayed in Table 6. The fan off delay time starts when the burner motor is de-energized at the end of a call for heat. Blower shutdown is delayed to remove any residual heat from the heat exchanger and improve the annual efficiency of the furnace.

The electronic fan timer board works in conjunction with snap disc limit controls, which perform a safety function, and breaks power to the oil burner primary control, which shuts off the burner if the furnace over-heats. The limit control is thermally operated and automatically resets. The limit control is factory installed, pre-set and is not adjustable.

If the limit control opens with the **United Technologies 1158-120 (WML-C and MPL-B)** electronic fan control, the circulating fan will be energized. When the limit closes, the control initiates a two-minute delay. When this delay is finished, the fan off timer will begin. At the end of the fan off time cycle the burner

will be energized, initiating a normal burner cycle.

**TABLE 5**  
**United Technologies 1158-120**

Dip Switch Position				Blower Delay Times	
1	2	3	4	On Sec-onds	Off Minutes
Off	Off			30	
On	Off			60	
Off	On			90	
On	On			120	
		Off	Off		2
		On	Off		3
		Off	On		4
		On	On		6

**Note: It is advisable not to set the fan on delay time for a time period longer than 90 seconds at highest input. Longer fan on delay times may result in nuisance limit trips.**

#### FAN TIMER BOARD AND LIMIT CONTROL (FIG. 8)(page 25)

The **United Technologies 1168-1 ECM (WMLV-C)** tap board has an adjustable fan on/off delay that must be adjusted in accordance with the furnace input rating (nozzle size). Refer to Table A-8a (page 17) for ECM blower set-up.

#### CIRCULATING AIR BLOWER (WML-C and MPL-B)

The WML-C / WMLV-C and MPL-B furnace models are equipped with a direct drive blower system. WML-C and MPL-B models are equipped with PSC motors; WMLV-C models are equipped with electronically commutated motors (ECM). Direct drive blower speed adjustments are not normally required in properly sized extended plenum duct systems. The motor RPM and air CFM delivery will vary automatically to accommodate conditions within the usual range of external static pressures typical of residential duct systems. Under-sized duct systems may require a higher blower speed to obtain a reasonable system temperature rise. Some older duct systems were not designed to provide static pressure. They typically feature special reducing fittings at each branch run and lack block ends on the trunk ducts. These systems may require modification to provide some resistance to the airflow to prevent over-amping of the direct drive blower motor.



Selecting a lower blower speed may correct this problem.

Direct drive blower speeds are adjusted by changing the "hot" wires to the motor winding connections. Please refer to wiring diagram in Appendix B or the wiring diagram label affixed to the furnace. **THE NEUTRAL WIRE (normally the white wire) IS NEVER MOVED TO ADJUST THE BLOWER SPEED.**

**CAUTION**

**DO NOT CONNECT POWER LEADS BETWEEN MOTOR SPEEDS. THE NEUTRAL WIRE MUST ALWAYS BE CONNECTED TO THE MOTOR'S DESIGNATED NEUTRAL TERMINAL.**

It is possible and acceptable to use a single blower speed for both heating and cooling modes. The simplest method to connect the wiring from both modes is to use a "piggy-back connector" accommodating both wires on a single motor tap. It is also acceptable to connect the selected motor speed with a pigtail joined to both heating and cooling speed wires with a wire nut. As a safety precaution against accidental disconnection of the wires by vibration, it is advisable to secure the wire nut and wires with a few wraps of electricians tape.

If the joining of the blower speed wiring is done in the furnace junction box, tape off both ends of the unused wire.

**CAUTION**

**DISCONNECT THE POWER SUPPLY TO THE FURNACE BEFORE OPENING THE BLOWER ACCESS DOOR TO SERVICE THE AIR FILTER, FAN AND MOTOR. FAILURE TO SHUT OFF POWER COULD ALLOW THE BLOWER TO START UNEXPECTEDLY, CREATING A RISK OF DEATH OR PERSONAL INJURY.**

Do not use the blower speed wires as a source of power to accessories as electronic air cleaners and humidifier transformers. The unused motor taps auto-generate sufficiently high voltages to damage accessory equipment. Use the terminals provided on the electronic fan timer.

**CAUTION**

**Do not start the burner or blower fan unless the blower access door is securely in place.**

Additional 1158-120 Fan Timer Control information is in Appendix B, Wiring Diagrams.

**HUMIDIFIER**

A humidifier is an optional accessory available through most heating supplies outlets. Installation should be carried out in accordance with the humidifier manufacturer's installation instructions. Water or water droplets from the humidifier should not be allowed to come into contact with the furnace heat exchanger. Do not use direct drive motor connections as a source of power for 120 VAC humidifi-

ers and humidifier transformers.

**OIL BURNER**

The oil burner must align properly with the cerafelt fiber chamber (firepot). The cerafelt fiber chamber is initially quite soft, but hardens and becomes quite brittle after the first firing. The firepot is held in place by a retaining bracket; however, it is possible for the firepot to shift if subjected to rough handling during transit.

**CAUTION**

**BEFORE OPERATING THE FURNACE CHECK BURNER ALIGNMENT WITH COMBUSTION CHAMBER. THE END CONE OF THE AIR TUBE MUST BE CENTRED TO THE ACCOMODATING RING PROVIDED IN THE DESIGN OF THE COMBUSTION CHAMBER. ADJUST ALIGNMENT AS NECESSARY BEFORE THE FIRST FIRING.**

**OIL BURNER NOZZLES**

WML-C / WMLV-C and MPL-B furnace models are certified for multiple firing rates, ranging from approximately 58,000 to 85,600 BTU/hr. on the WML-C / WMLV-C, and 85,500 to 123,000 BTU/hr. on the MPL-B. By changing the oil burner nozzle within the specific model range, and temperature rise, the furnace may be fired at an ideal rate for a wide range of structures.

Figure 4: Horizontal Smoke Test Port Location

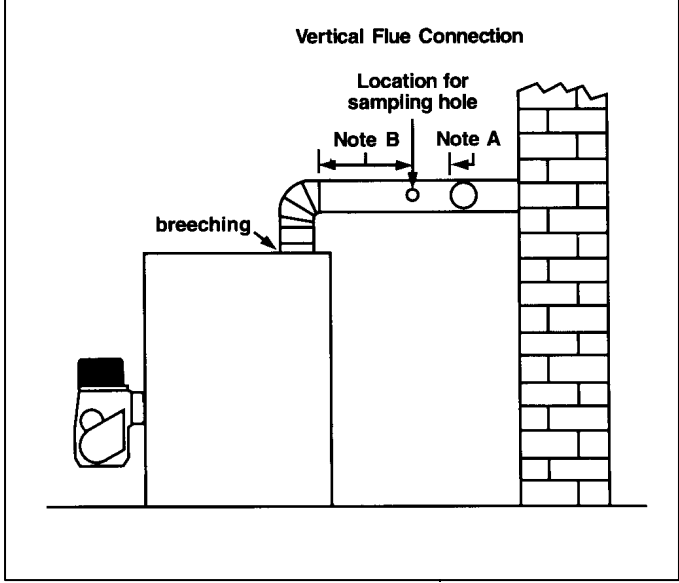
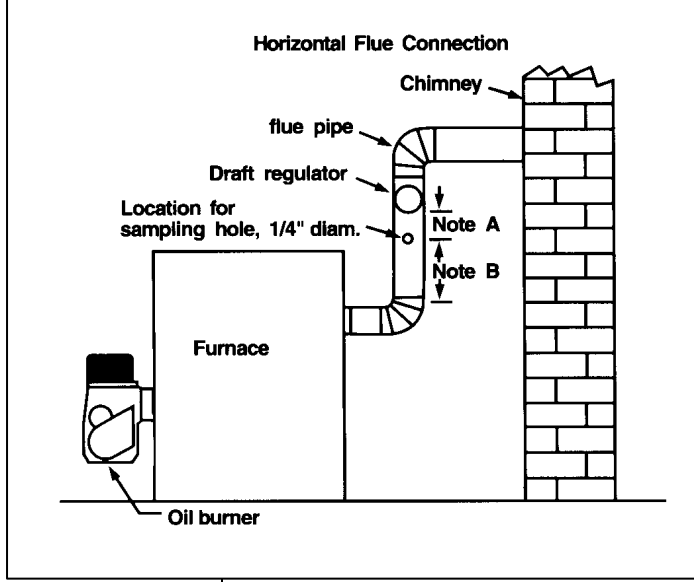

Figure 5: Vertical Smoke Test Port Location



## BURNER ELECTRODES

Correct positioning of the electrode tips with respect to each other, to the fuel oil nozzle, and to the rest of the burners is essential for smooth light ups and proper operation. The electrode tips should be adjusted to a gap of 5/32", 1/16" ahead of the nozzle, 5/16" above the centerline of the nozzle. The "Z" dimension (front edge of the burner head to the front face of the nozzle is 1-1/8 inches.

Electrode positioning should be checked before the first firing of the furnace.

The electrode porcelains should be free of cracks, the electrode tips should be tapered and free of burrs, and the contact rods must be clean and be in firm contact with the ignition transformer contact springs. The electrodes must not come into contact with the burner head.

## OIL BURNER SET-UP

The burner air supply is adjusted to maintain the *fuel to air ratio* to obtain ideal combustion conditions. A lack of air causes "soft" and "sooty" flames, resulting in soot build-up throughout the heat exchanger passages. Excess combustion air causes a bright roaring fire and high stack temperatures resulting in poor fuel efficiency.

## PREPARATIONS:

Drill a 1/4" test port in the venting, ideally at least 2 flue pipe diameters away from the furnace breeching, if venting horizontally from the furnace, or from the flue pipe elbow if venting vertically before reaching the furnace. (See Figures 4 and 5).

The test port will allow flue gas samples to be taken and stack temperatures to be measured.

Before starting the burner, check the burner alignment with the combustion chamber (fire pot), check that the correct nozzle is tightened into place, and that the burner electrodes are properly positioned.

The Beckett burner bulk air band should be closed, and the air shutter initial setting should be approximately 7.00.

**Note A:** Locate hole at least 6 inches on the furnace side of the draft control.

**Note B:** Ideally, hole should be at least 12 inches from breeching or elbow.

## PROCEDURE:

Start the burner and allow it to run at least ten minutes. Set the air shutter to give a good flame visually. The combustion air supply to the burner is controlled by manipulating the air shutter on the left side of the burner, and, if necessary, the bulk air band. To adjust, loosen the bolt on the movable shutter. Move the shutter gradually until a good flame (visually) has been achieved. Re-slug the bolt.

Check the initial draft setting as the furnace warms up. The draft may be measured at the test port. The breech draft should be approximately - 0.05" w.c. to obtain an over fire draft reading of - 0.02 inches w.c.

Check the oil pump pressure. Standard operating pressure is 100 PSIG.

After reaching steady state, take a smoke test. If not indicating a trace, set the combustion air controls to provide a trace.

Typically, the CO<sub>2</sub> reading will range from 11.5% to 13.5%.

After the air adjustments have been completed, and the air shutter or air adjustment plate has been secured, re-check the over fire draft and take another smoke test to ensure that the values have not changed.



Figure 6: Checking Over-Fire Draft.

## SMOKE TEST NOTE:

If oily or yellow smoke spots are found on the smoke test filter paper, it is usually a sign of unburned fuel. This indicates poor combustion. This type of problem may be caused by excess draft,

excess air, or contaminated fuel. Do not ignore this indicator.

## STACK TEMPERATURE:

Stack temperature will vary depending on fuel input, circulating air blower speed, and burner set up, etc. In general, stack temperature should typically range between 380°F to 550°F, assuming that the combustion air is approximately room temperature (65°F - 70°F). In general, lower stack temperature indicates greater efficiency; however, excessively low stack temperature can lead to condensation forming in the chimney and / or venting. Sulphur and similar contaminants in the fuel oil will mix with condensation to form acids. Acids and resultant chemical salts will cause rapid deterioration of the chimney and venting components, and may attack the furnace heat exchanger.

If the flue gases are below the range, it may be necessary to slow down the blower fan. If the flue gases are above the range, the blower fan may require speeding up. Stack temperature varies directly with the system temperature rise. System temperature rise is the difference between the furnace outlet temperature and furnace inlet temperature as measured in the vicinity of the connection between the plenum take-offs and the trunk ducts.

If the venting from the furnace to the chimney is long, or exposed to cold ambient temperatures, it may be necessary to use L-Vent as the vent connector to reduce stack temperature loss to prevent condensation. The venting should be inspected annually to ensure that it is intact.

## FURNACE INSTALLATION SET-UP

The furnace must be set up as the final step in the installation.

A) The oil burner must be set up following the procedures outlined above.

B) The WML-C / WMLV-C and MPL-B models should operate within the temperature rise as listed on the furnace rating plate. To determine the temperature rise, measure the supply air and return air temperatures when the furnace has reached steady state conditions. This is the point at which the supply air temperature stops increasing relative to the return air temperature. The furnace may have to run 10 to 15 minutes to reach steady state conditions. The measurements may be made with duct thermometers or thermocouples used in

conjunction with multi-meters with temperature measurement capabilities.

The return air should be measured at a point where the thermometer will be well within the air stream near the furnace return air inlet. Actual location is not particularly critical; however, avoid locations where the temperature readings could be affected by humidifier bypass ducts, the inside radius of elbows, etc.

The supply air temperature should be measured at a point where the thermometer will be well within the air stream near the furnace supply air outlet. Usually, the side mid-point of the supply air plenum take-off is ideal, providing it is out of the line of sight to the heat exchanger. If the thermometer is within the line of sight of the heat exchanger, the supply air readings may be skewed by radiant heat from the heat exchanger. If the plenum take-off is unsuitable, the supply air temperature may be measured within the first 18 inches of the first segment of supply air trunk duct.

If the temperature rise is outside the recommended range, it may be adjusted on direct drive equipped units by selecting alternate circulation fan motor speeds. If the temperature rise is too high, speed the fan up. If the temperature rise is too low, slow the fan down.

C) Keep in mind that the stack temperature varies directly with the temperature rise. The higher the temperature rise, the higher the stack temperature will be, resulting in lower efficiency. The lower the temperature rise, the lower the stack temperature will be, which, in some cases, may allow condensation to form in the chimney and other vent parts.

D) Test the high limit control to ensure that it is operating correctly. This may be done by temporarily removing the circulator fan heating wire or neutral wire. Turn off electrical power to the furnace before working with the motor wires. Be sure to protect any removed wires from shorting out on metal furnace parts. If the high limit test is successful, shut off the electrical power to the furnace, restore the proper motor wiring. Finally, restore power to the furnace.

E) Operate the furnace through a minimum of three full heating cycles. During this time, check for fuel oil leaks, gross air leakage from the supply air ductwork, unusual noises originating anywhere within the heating system which may cause some concern or annoyance to the home owner, etc.

F) Be sure that the homeowner is familiar with the furnace. The homeowner should be aware of the location of electrical circuit breaker or fuse, the location of any electrical switches controlling the furnace, the location of the oil tank shut-off valve and how to operate the valve. The homeowner should be informed where the oil tank gauge is located and how to read it.

It would be beneficial to review safety issues with the home owner, such as the danger of storing combustibles too close to the furnace, hanging anything on the furnace vent pipe, and especially the dangers of indiscriminately pressing the burner reset button.

**IMPORTANT:** Be sure that the home owner knows where the burner reset switch is located, and is aware that the reset switch is not to be activated more than once without a thorough look for the cause of the problem, (lack of fuel, etc.). Be sure that the homeowner knows when to quit trying to start the furnace during these conditions and who to call for emergency service.

#### MAINTENANCE AND SERVICE

##### A: Routine Maintenance By Home Owner

Other than remembering to arrange for the annual professional servicing of the furnace by the service or installation contractor, the most important routine service performed by the homeowner is to maintain the air filter or filters. A dirty filter can cause the furnace to over-heat, fail to maintain indoor temperature during cold weather, increase fuel consumption and cause component failure.

The furnace filter(s) should be inspected, cleaned or replaced monthly. The furnace is factory equipped with a semi-permanent type filter. If the filter is damaged, replace with filters of the same size and type.

During the routine service, inspect the general condition of the furnace watching for signs of oil leaks in the vicinity of the oil burner, soot forming on any external part of the furnace, soot forming around the joints in the vent pipe, etc. If any of these conditions are present, please advise your service or installation contractor.

##### B: Annual Service By Contractor

### **CAUTION**

**THE COMBUSTION CHAMBER (FIRE-POT) IS FRAGILE. USE CARE WHEN INSPECTING AND CLEANING THIS AREA.**

The heat exchanger should be inspected periodically and cleaned if necessary. If cleaning is necessary, **SHUT OFF POWER TO THE FURNACE** and remove the burner. Using a stiff brush with a wire handle, brush off scale and soot from inside the drum and flue pipe. To clean the radiator, remove the round cover or covers on the inner radiator access pipes located on the front panel between the oil burner and the flue pipe. Rear breech models have a single front cleanout and front breech models have two front cleanouts.

A wire brush can be used to loosen dirt and debris on the inside surfaces of the radiator. Clean out all accumulated dirt, soot and debris with a wire handled brush and an industrial vacuum cleaner. Replace the clean-out covers.

The blower motor is factory oiled and permanently sealed. **DO NOT LUBRICATE.** Excess oil may result in premature electric motor failure.

Inspect the blower fan. Clean it if necessary.

Oil Burner Maintenance: Follow the instructions of the oil burner manufacturer. (See oil burner manufacturer's instructions supplied with furnace). The oil burner nozzle should be replaced annually. We recommend that the oil filter be changed on an annual basis.

The venting system should be cleaned and inspected for signs of deterioration. Replace pitted or perforated vent pipe and fittings. The barometric draft regulator should open and close freely.

All electrical connections should be checked to ensure tight connections. Safety controls such as the high limit controls should be tested for functionality. The fan control functions should be checked to ensure that all fan speeds are operating properly.

## OPERATING INSTRUCTIONS (WML-C and MPL-B)

### Before Lighting

1. Open all supply and return air registers and grilles.
2. Open all valves in oil pipes.
3. Turn on electric power supply

### To Light Unit

1. Set the thermostat above room temperature to call for heat. The burner should start. NOTE: It may be necessary to press the RESET button on the primary combustion control relay.
2. There will be a fan on time delay before the circulating fan is energized. The **United Technologies 1158-120** has an adjustable fan on time that is set by selecting the dipswitch combination displayed in Chart 1. This fan on delay can be set at 30, 60, 90 or 120 seconds.
3. Set the thermostat below room temperature. The oil burner should stop.
4. The air circulation blower will continue to run until the time off setting selected on the electronic fan timer control times out. The **United Technologies 1158-120** has an adjustable fan off time of 2, 3, 4, or 6 minutes. The fan timer control adjustments may be altered if the air at the room registers is uncomfortably high upon blower start up or shutdown.
5. The necessary adjustments to the fan control settings should be determined by measuring the temperature of the air in the supply air take-off, or within the first few inches of the supply air trunk. The side mid point of the transition is usually ideal, providing that the thermometer probe is beyond the "line of sight" wherein false readings from radiant heat could be observed. The system temperature rise, *the difference in temperature between the supply air and return air*, should be within the indicated range on the appliance rating plate.

To check the operation of the limit switch, shut off power to the furnace. Temporarily remove the neutral wire from the direct drive blower motor. Restore the electrical power to the furnace and set the thermostat above room temperature. After three or four minutes of burner operation, the limit control should turn the burner off. When the limit function test is complete, shut off electrical power to the furnace, replace the neutral wire to the blower fan motor, and then restore power. The blower fan will start up immediately. Once the temperature

has dropped and the limit control has reset, the fan will operate until the fan off time is achieved. The oil burner will then resume operation and continue until the thermostat is satisfied. Restore the thermostat setting to a comfortable temperature.

### To Shut Down Unit

1. Set the thermostat to the lowest possible setting.
2. Set the manual switch (if installed) in the Electrical Power Supply Line to "OFF".

## OPERATING INSTRUCTIONS (WMLV-C)

Refer to steps 1, 3, and 5 in the previous section.

There will be a fan on time delay before the circulating fan is energized. The United Technologies 1168-1 has an adjustable fan on time that is programmed into the ECM motor, and is set by selecting the SW4 DIP switch combination displayed in Table A-8a page 17. Fan on delay must be adjusted according to input (nozzle size).

To check the operation of the limit switch, shut off power to the furnace. Temporarily remove the 5 pin power connector plug from the ECM blower motor. **NOTE: Isolate the AC Line pins on the 5 pin power connector with electrical tape to prevent electric shock hazard.** Restore the electrical power to the furnace and set the thermostat above room temperature.

After three or four minutes of burner operation, the limit control should turn the burner off. When the limit function test is complete, shut off electrical power to the furnace, replace the 5 pin power plug to the blower fan motor, and then restore power. The blower fan will start up immediately. Once the temperature has dropped and the limit control has reset, the fan will operate until the fan off time is achieved.

The oil burner will then resume operation and continue until the thermostat is satisfied. Restore the thermostat setting to a comfortable temperature.

**NOTE: If the furnace is to be shut down for an extended period of time, close the oil supply valve to the oil burner.**

## ⚠ WARNING

**DO NOT ATTEMPT TO START THE BURNER WHEN EXCESS OIL HAS ACCUMULATED, WHEN THE FURNACE IS FULL OF VAPOUR, OR WHEN THE COMBUSTION CHAMBER IS VERY HOT. NEVER BURN GARBAGE OR PAPER IN THE FURNACE, AND NEVER LEAVE PAPER OR RAGS AROUND THE UNIT.**

## ECM BLOWER MOTOR OPERATION

### Setting Blower "ON" and "OFF" Timings

Blower on/off delays are handled by ECM programming. Features of this ECM variable speed motor are that it will deliver a constant airflow within a wide range of external static pressures, and also includes:

**Soft Start:** This ECM variable speed motor will slowly ramp up to the required operating speed. This feature in the heating cycle allows the heat exchanger to reach operating temperature before the set heat speed, which minimizes noise and increases comfort.

**Soft Stop:** At the end of the heating cycle, the ECM variable speed motor will slowly ramp down. This feature allows for increased energy efficiency and reduced noise levels.

**Dehumidification:** A dehumidification feature has been programmed into the variable speed motor. At the start of each cooling cycle, the variable speed motor will run at 82% of the rated air flow for 7.5 minutes. After 7.5 minutes has elapsed, the motor will increase to 100% of the rated airflow. This profile is used to provide dehumidification and improve system efficiency.

**Continuous Fan Operation:** When the thermostat continuous fan (G) switch is on without a call for heating or cooling, the indoor fan is immediately energized up to 50% of the cooling speed. This feature allows continuous circulation of air between calls for heating or cooling.

If a call for heat (W) or cool (Y) occurs during continuous fan, the blower will remain energized.

## APPENDIX A- WML-C / WMLV-C and MPL-B BURNER SET UP

WML-C / WMLV-C and MPL-B furnaces may be used with the following oil burners.

**Please note:** The Beckett AF, and Riello 40F oil burners are for applications using indoor air for combustion only. For sidewall venting applications utilizing outdoor air for combustion, use the Beckett AFII or the Riello 40BF (Balanced Flue) oil burners only.

**Table A-1 Beckett AF Oil Burner Set-Up**

<b>Beckett AF Series Oil Burners</b> (For use with chimney vented units only)							
<b>Furnace Model</b>	<b>Output BTU/Hr</b>	<b>Burner Model</b>	<b>Nozzle</b>	<b>Pump Pressure</b>	<b>Flow Rate</b>	<b>Head <sup>1</sup></b>	<b>Static Plate</b>
WML-60C <sup>2</sup> WMLV-60C <sup>2</sup>	58,000	AF76BNHS	0.50 / 80°A	100 PSIG	0.50 USGPH	F3	3- 3/8 in.
WML-80C WMLV-80C	75,000	AF76BNHS	0.65 / 80°A	100 PSIG	0.65 USGPH	F3	3- 3/8 in.
WML-90C WMLV-90C	85,600	AF76BNHS	0.75 / 80°A	100 PSIG	0.75 USGPH	F3	3- 3/8 in.
MPL-90B	85,500	AF76XN	0.75 / 80°A	100 PSIG	0.75 USGPH	F3	2- 3/4 in.
MPL-100B	96,000	AF76XN	0.85 / 80°A	100 PSIG	0.85 USGPH	F3	2- 3/4 in.
MPL-120B	112,000	AF76XN	1.00 / 60°A	100 PSIG	1.00 USGPH	F3	2- 3/4 in.
MPL-130B	123,000	AF76YB	1.10 / 70°A	100 PSIG	1.10 USGPH	F6	2- 3/4 in.

<sup>1</sup> Head is shielded by ceramic insulator. <sup>2</sup> Low Firing Rate Baffle required when using a 0.50-gallon nozzle.

**Table A-2 Beckett AFII Oil Burner Set-Up**

<b>Beckett AFII Series Oil Burners</b> (For use with sidewall vented units using outdoor combustion air)						
<b>Furnace Model</b>	<b>Output BTU/Hr</b>	<b>Burner Model</b>	<b>Nozzle</b>	<b>Pump Pressure</b>	<b>Flow Rate</b>	<b>Head</b>
WML-60CB2U WMLV-60CB2U	63,500	AFII-85	0.50 / 60°A	145 PSIG	0.55 USGPH	FB0
WML-80CB2U WMLV-80CB2U	75,000	AFII-85	0.60 / 60°A	145 PSIG	0.65 USGPH	FB3
WML-90CB2U WMLV-90CB2U	85,600	AFII-85	0.70 / 60°A	145 PSIG	0.75 USGPH	FB3
MPL-90CB2U	85,500	AFII-150	0.70 / 60°A	145 PSIG	0.75 USGPH	FB0
MPL-100CB2U	96,000	AFII-150	0.80 / 60°A	145 PSIG	0.85 USGPH	FB3
MPL-120CB2U	112,000	AFII-150	0.85 / 70°A	145 PSIG	1.00 USGPH	FB3

**Table A-3 Riello 40F Series Oil Burner Set-Up**

<b>Riello 40F Series Oil Burners</b> (For use with chimney vented units)							
<b>Furnace Model</b>	<b>Output BTU/Hr</b>	<b>Burner Model</b>	<b>Nozzle</b>	<b>Pump Pressure</b>	<b>Flow Rate</b>	<b>Air Gate</b>	<b>Turbulator Setting</b>
WML-60CRF WMLV-60CRF	59,500	40F3	0.50 / 60°W	105 PSIG	0.51 USGPH	2.6	1.0
WML-80CRF WMLV-80CRF	75,000	40F3	0.60 / 60°W	115 PSIG	0.65 USGPH	2.6	1.5
WML-90CRF WMLV-90CRF	85,600	40F3	0.65 / 60°W	135 PSIG	0.75 USGPH	3.6	2.0
MPL-90BRF	85,500	40F5	0.60 / 60°W	145 PSIG	0.75 USGPH	2.25	0.0
MPL-100BRF	96,000	40F5	0.65 / 60°W	145 PSIG	0.85 USGPH	2.5	0.5
MPL-120BRF	112,000	40F5	0.85 / 60°W	145 PSIG	1.00 USGPH	2.75	1.0

**Table A-4 Riello Balanced Flue (BF) Burner Set-Up**

<b>Riello Balanced Flue Series Oil Burners</b> (For use with sidewall vented units using outdoor combustion air)						
<b>Furnace Model</b>	<b>Output BTU/Hr</b>	<b>Burner Model</b>	<b>Nozzle</b>	<b>Pump Pressure</b>	<b>Flow Rate</b>	<b>Turbulator Setting</b>
WML-60CRBU	59,500	40BF3	0.50 / 60°W	105 PSIG	0.51 USGPH	1.0
WML-80CRBU	75,000	40BF3	0.60 / 60°W	115 PSIG	0.65 USGPH	1.5
WML-90CRBU	85,600	40BF3	0.65 / 60°W	135 PSIG	0.75 USGPH	2.0

**NOTE: Air gate setting may vary for sidewall vented units where air gate must be adjusted to achieve zero smoke.**

## A.1 OIL BURNER AIR ADJUSTMENT

For complete details, consult the oil burner instruction manual provided in the furnace documents envelope.

### Beckett AF Burner

Adjust the air shutter by loosening the locking screws and moving the air shutter, and if necessary, the bulk air band.

### Beckett AFII Burner

Adjust the burner air supply by first loosening the locking screw located on the black dial to the right of the burner. Turn the black dial clockwise to increase the combustion air and counter-clockwise to decrease the combustion air. Re-tighten the locking screw after obtaining the proper setting.

### Riello 40 Series (Chimney Vented)

Riello burners are factory set with respect to nozzle size; pump pressure, air gate and turbulator adjustments for each model and firing rate. By removing the burner cover and loosening the screws that secure the air adjustment plate, the combustion air can be adjusted. Move the adjusting plate to either increase or decrease combustion air. When the proper air setting is achieved, retighten the fixing screws.

### Riello Balanced Flue (BF) Series

Riello burners are factory set with respect to nozzle size; pump pressure, and turbulator adjustments for each model and firing rate. The combustion air can be adjusted with the burner cover on by first removing the plastic cover on the top right hand side of the burner cover. With a Philips head screw driver, turn the adjustment screw clockwise to increase combustion air or counter-clockwise to decrease combustion air. When the combustion air is set, re-insert the plastic cover.

## A.2 BURNER ELECTRODES

Adjustment of the electrode tips with respect to each other, the nozzle, and to the rest of the burner is very important to ensure smooth start-ups and to permit efficient combustion.

### Beckett AF Burner

Electrode gap: 5/32 inch.

Distance above horizontal centerline: 5/16 inch. Older instruction sheets specify 7/16 inch. The current specification is 5/16 inch.

Distance ahead of nozzle: 1/16 inch.

"Z" dimension, the distance from the front of the end cone (head) to the face of the nozzle should be 1-1/8 inches. If a ceramic head is used, the distance from the end cone to the nozzle face is increased to 1-3/8 inches.

### Riello 40F, & BF Burners

Electrode gap: 5/32 inch.

Distance above horizontal centerline: 13/64 inch.

Distance ahead of nozzle: 5/64 to 7/64 inch.

## A.3 START UP

The furnace should be operated for a minimum of 15 minutes to reach steady state conditions before fine tuning combustion. The warm up time is ideal for testing the oil pump pressure.

Drill a 1/4-inch test port in the venting between the furnace flue outlet and draft regulator (barometric damper). Insert a stack thermometer and note the flue gas temperature. The flue gases should be within a range of 350°F to 450°F. If the flue gases are below the range, it may be necessary to slow down the blower fan. If the flue gases are above the range, the blower fan may require speeding up. Stack temperature varies directly with the system temperature rise. System temperature rise is the difference between the furnace outlet temperature and furnace inlet temperature as measured in the vicinity of the connection between the plenum take-offs and the trunk ducts

Perform a smoke spot test. The smoke spot should not exceed No. 1 on the Bacharach Scale.

After the air adjustments have been completed, re-check the draft pressure at the test port on the burner mounting plate as shown in Figure 6. The draft should be adjusted to -0.02 inches w.c.

In the United States, the Beckett AF Burner may be equipped with Beckett's "Inlet Air Shut-Off" to increase efficiency. (Beckett Part No. AF/A 5861).

**NOTE: USE OF THE INLET AIR SHUT-OFF COULD CAUSE POST COMBUSTION NOZZLE DRIP.**

## A.4 SPECIAL INSTRUCTIONS FOR UNITS EQUIPPED WITH RIELLO BURNERS

Riello burners are factory set with respect to nozzle size, pump pressure, air gate and turbulator adjustments for each model and firing rate; therefore, do not use the above listed set up procedures.

Riello specifications are listed in Tables A-3 and A-4. Consult the Riello Installation Instructions supplied with the Burner for specific information concerning burner adjustments, operation, and trouble-shooting.

**Table A-6 Direct Drive Blower Set-Up**

Furnace Model	Blower	Blower Set-Up				Cooling Capacity		
		0.20 in. w.c.		0.50 in. w.c.		Tons	Power	CFM Range
		Speed	Motor	Speed	Motor			
WML-60C	100-10T DD	Low	½ HP	Med-Low	½ HP	3	½ HP	763 – 1505
WML-80C	100-10T DD	Med-Low	½ HP	Med-High	½ HP	3	½ HP	763 – 1505
WML-90C	100-10T DD	Med-High	½ HP	High	½ HP	3	½ HP	763 – 1505
MPL-90B	120-10 DD	Low	¾ HP	Med-High	¾ HP	3	¾ HP	1185 – 1553
MPL-100B	120-10 DD	Med-High	¾ HP	High	¾ HP	3	¾ HP	1185 – 1553
MPL-120B	120-10 DD	High	¾ HP	High	¾ HP	3	¾ HP	1185 – 1553
MPL-130B	120-10 DD	High	¾ HP	High	¾ HP	3	¾ HP	1185 – 1553

**Table A-8 Direct Drive Blower Characteristics**

Furnace Model	Blower	Motor HP	Motor FLA	ΔT	Speed	CFM			
						External Static Pressure – Inches w.c.			
						0.20	0.30	0.40	0.50
WML-C 60 - 90	100-10T DD	½ HP	7.0	60°F	LOW	813	813	797	763
					MED-LOW	1170	1144	1118	1063
					MED-HIGH	1423	1381	1291	1220
					HIGH	1505	1444	1359	1291
MPL-B 90-130	120-10 DD	¾ HP	12.5	65°F	LOW	1334	1286	1239	1185
					MED-LOW	1389	1332	1287	1236
					MED-HIGH	1423	1373	1326	1289
					HIGH	1553	1491	1449	1331

Furnace Model	Blower	Motor HP	Motor FLA	ΔT	CFM RANGE		
					Continuous Fan	Heating	Cooling
						0.38 - 0.48 inches w.c.	0.5 inches w.c.
WMLV-C 60 – 90	100-10T DD	1/2 HP ECM	7.7	60°F	525 - 700	825 - 1250	600 - 1200

**TIP: These Formulae will assist with the design of the ductwork and the determination of air flow delivery:**

CFM = Bonnet Output / (1.085 x System Temp Rise)  
 System Temp Rise = Bonnet Output / (1.085 x CFM)



**Table A-8a ECM Blower Set-Up**

DIP SWITCH ADJUSTMENT CHART  
FOR INPUT 0.50 USGPH TO 0.75 USGPH

SW1 - HEAT		POS.	INPUT USGPH
DIP Switch Position			
1	2		
OFF	OFF	A	0.65
ON	OFF	B	0.75
OFF	ON	C	0.50
ON	ON	D	N/A

SW2 - COOL		POS.	AC Size (TON)
DIP Switch Position			
1	2		
OFF	OFF	A	3
ON	OFF	B	2.5
OFF	ON	C	2
ON	ON	D	1.5

SW3 - ADJUST		POS.	CFM
DIP Switch Position			
1	2		
OFF	OFF	A	0%
ON	OFF	B	(+)15%
OFF	ON	C	(-)15%
ON	ON	D	N/A

SW4 - DELAY		POS.	INPUT USGPH
DIP Switch Position			
1	2		
OFF	OFF	A	0.65
ON	OFF	B	0.75
OFF	ON	C	0.50
ON	ON	D	N/A

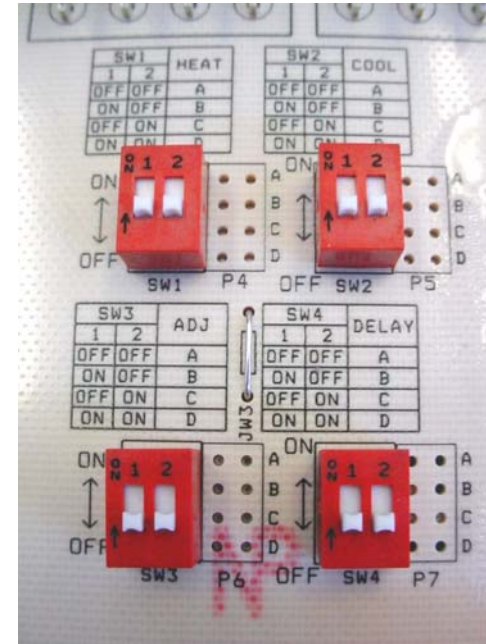

**NOTE:**

**SW1 (HEAT) AND SW4 (DELAY) DIP SWITCHES MUST BOTH BE ADJUSTED ACCORDING TO INPUT (NOZZLE SIZE).**

**SW2 (COOL): 1 TON is approximately equal to 400 CFM**

**SW3 (ADJUST): (Heating Mode) Increase OR decrease temperature rise respectively**

**(Cooling Mode) Increase OR decrease CFM respectively**

**Table A-9 General Dimensions (Inches)**

Furnace Model	Cabinet			Plenum Openings			Flue Diameter H	Filter		Shipping Weight lbs
	Width A	Depth B	Height C	Supply D x E	Return			Type	Size	
					Side	Bottom				
WML-C / WMLV-C	22	22-1/8	55-1/4	19 x 19	18 x 18	18 x 18	5	Permanent	20 x 20 x 1	265
MPL-B	22-1/4	22-1/4	62	20-1/2 x 20-1/2	18 x 18	18 x 18	6	Permanent	20 x 20 x 1	292

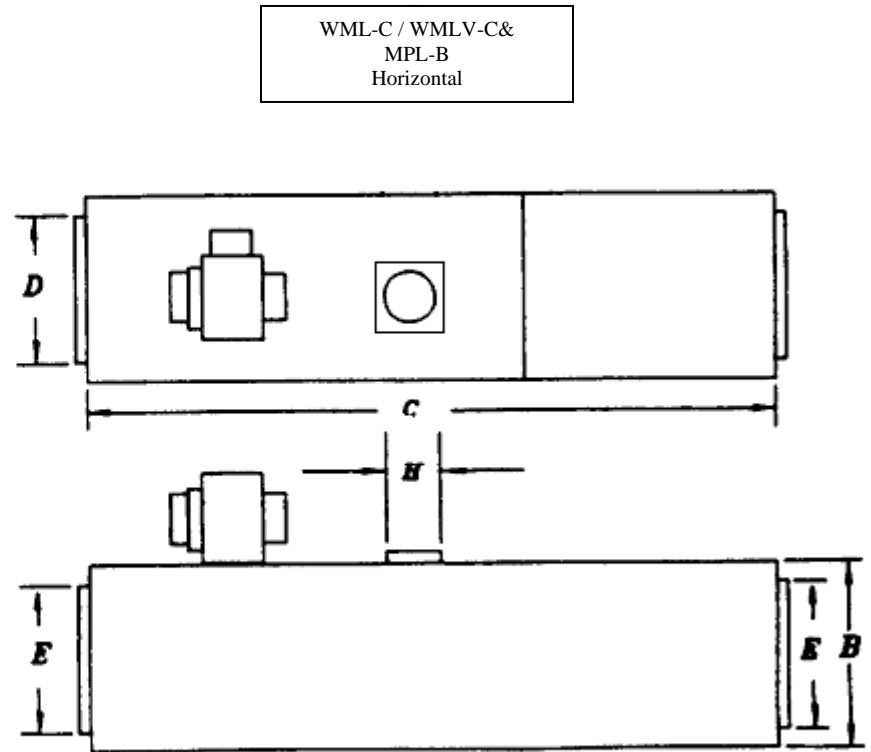
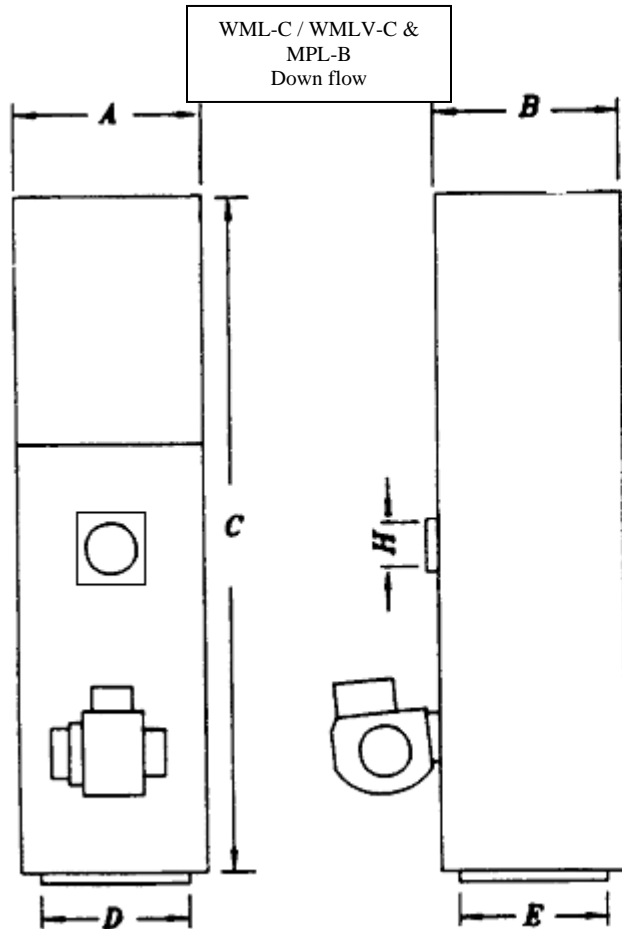

# APPENDIX B: WIRING DIAGRAMS

## Chimney Vent Burner Wiring Diagram WML-C WMLV-C MPL-B

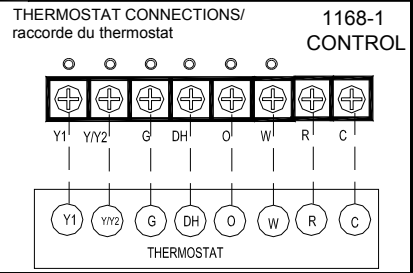
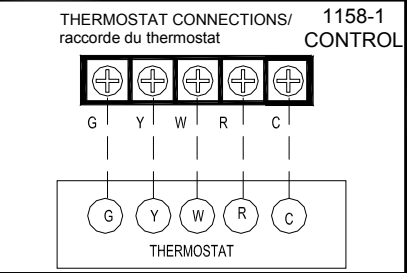
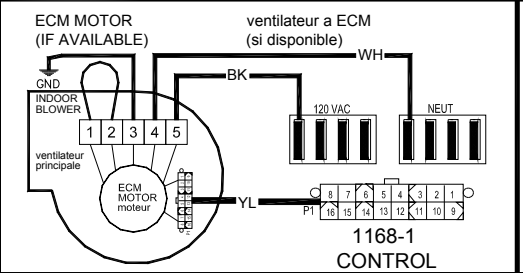
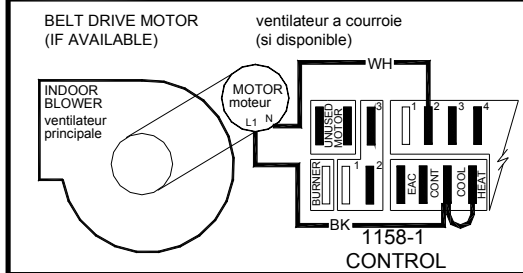
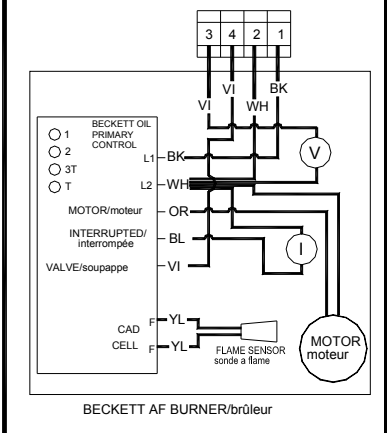
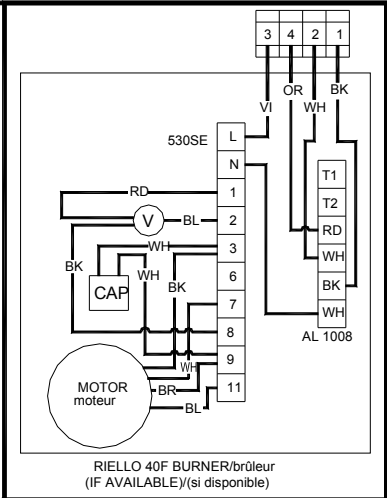
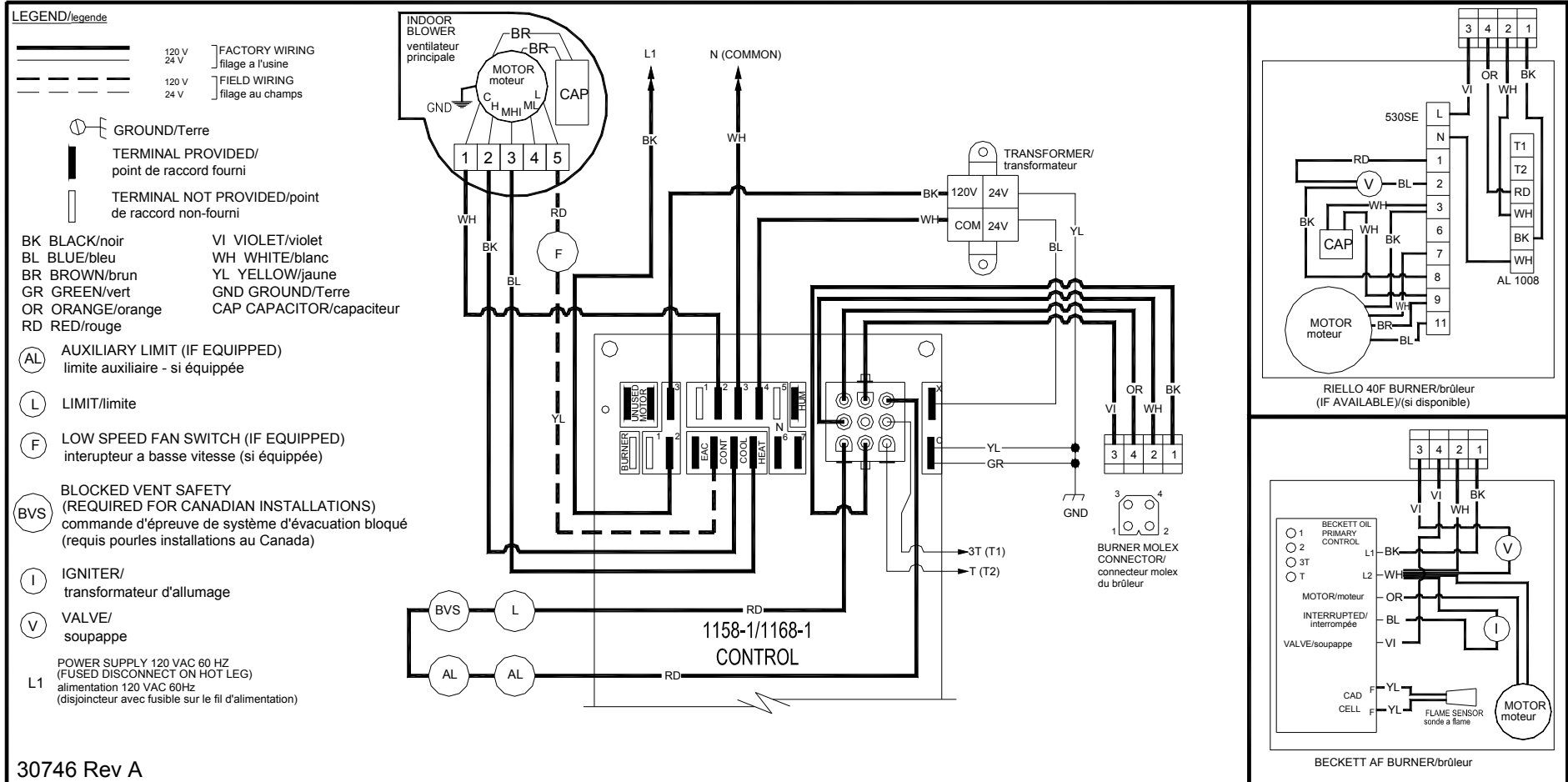

# Direct Vent Burner Wiring Diagram WML-C WMLV-C MPL-B

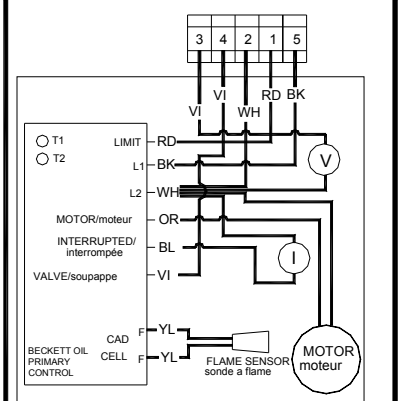
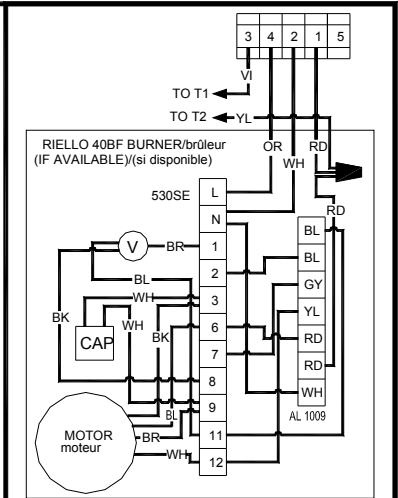
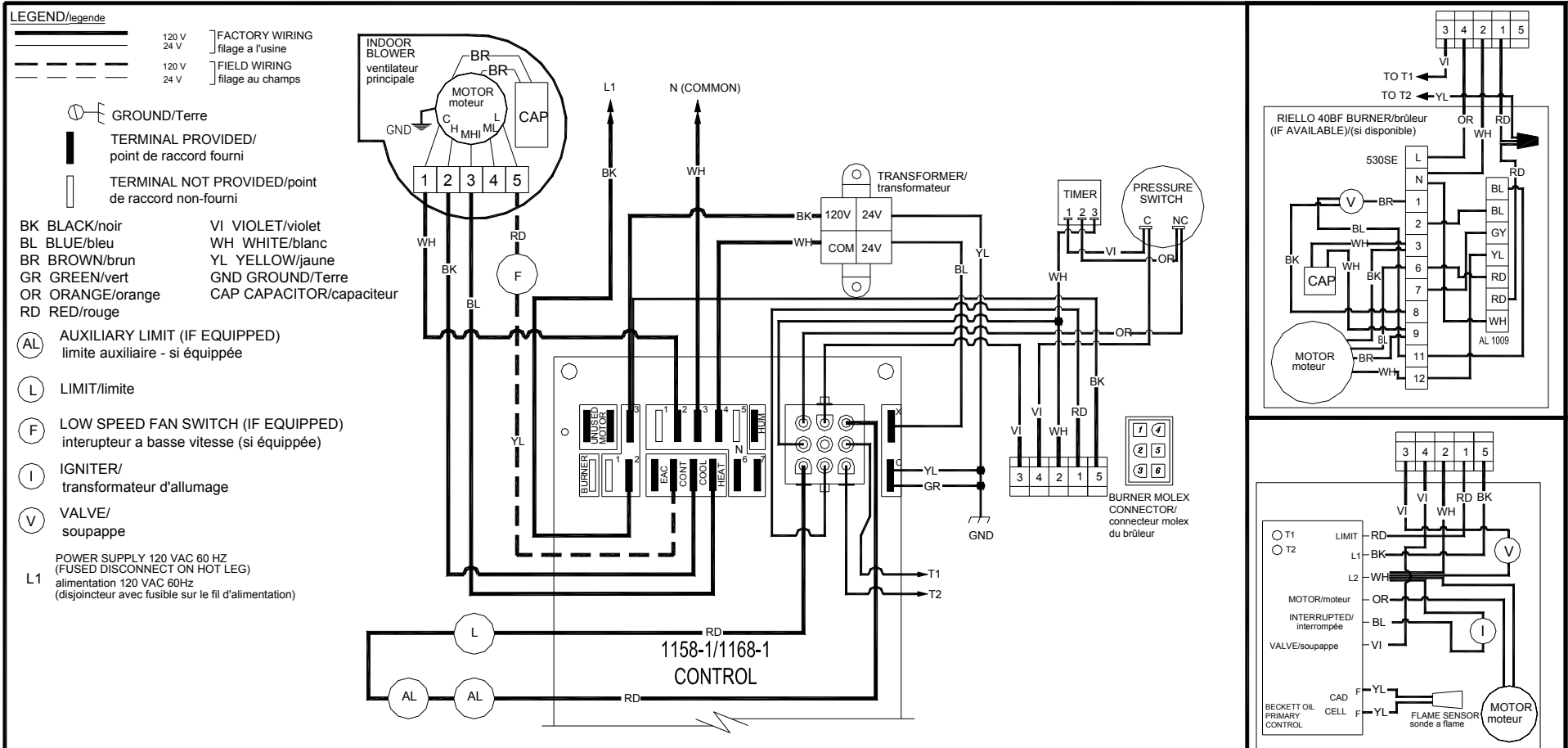

240005212 Rev A

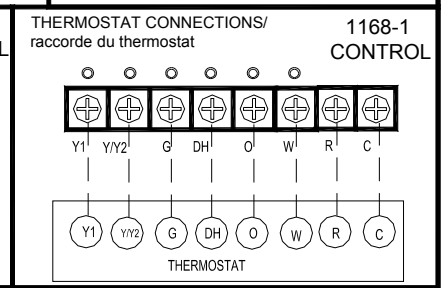
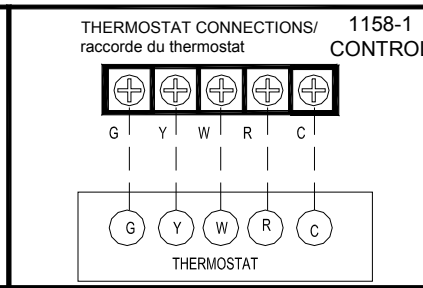
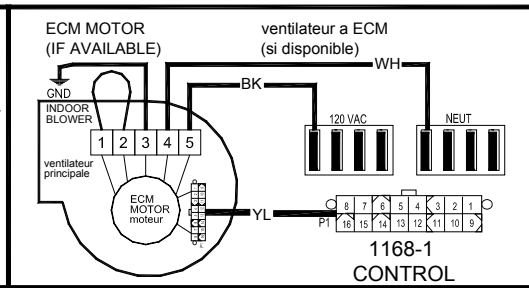
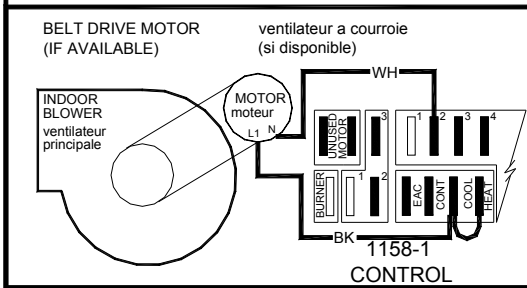

## OPERATION OF OIL BURNER

Once the furnace flue pipe, electrical and oil line connections have been made, use the following instructions to set the burner:

Shut off the electrical power to the furnace.

Install an oil pressure gauge to the pressure port on the oil pump. (Refer to the oil pump specification sheet included with the burner instructions).

Restore electrical power to the furnace.

Start the furnace and bleed all air from the fuel oil lines.

Close the purge valve and fire the unit.

Allow the furnace to warm up to normal operating temperatures. During this time, set the pump pressure in accordance with the data provided in Appendix A, Table A-2, and A-5.

When the furnace has reached "steady state" (after approximately 15 minutes). Set combustion air damper to get a TRACE of smoke.

Check the system temperature rise. *The temperature rise is the difference between the return air temperature measured at a point near the return air inlet, and the supply air temperature measured near the furnace outlet.* If the temperature rise is too high, the airflow must be increased. If the temperature rise is too low, the fan should be slowed down.

Turn off the burner. Observing the duct thermometer in the supply air stream, note the temperature at which the blower fan stops. The fan adjustments can be made by moving the dipswitch settings on the timer control board for fan off delay.

To check the operation of the limit switch, shut off power to the furnace. Temporarily remove the neutral wire from the direct drive blower motor. Restore the electrical power to the furnace and set the thermostat above room temperature. After three or four minutes of burner operation, the limit control should turn the burner off. When the limit function test is complete, shut off electrical power to the furnace, replace the neutral wire to the blower fan motor, and then restore power. The blower fan will start up immediately. Once the temperature has dropped and the limit control has reset, the fan will operate until the fan off time is achieved. The oil burner will then resume operation and

continue until the thermostat is satisfied. Restore the thermostat setting to a comfortable temperature.

Set the heat anticipator adjustment in the thermostat (if so equipped), by removing the "R" or "W" wire to the thermostat, then reading the amperage draw between the two wires. Failure to remove one of the wires from the thermostat while performing this test could burn out the heat anticipator. Set the heat anticipator to the amperage measured.

**NOTE: THE FURNACE SHOULD BE RUN THROUGH AT LEAST THREE FULL CYCLES BEFORE LEAVING THE INSTALLATION, TO ENSURE THAT ALL CONTROLS ARE OPERATING PROPERLY AND AS EXPECTED.**

**NOTE: ALL JOINTS IN ANY POSITIVE PRESSURE VENTING SYSTEM MUST BE CHECKED FOR LEAKS BEFORE LEAVING THE INSTALLATION SITE.**

## APPENDIX C OIL PRIMARY CONTROL DETAILED SEQUENCE OF OPERATION

Power is applied to unit. The oil primary control completes a self-diagnostic procedure. If no light or flame is present, and unit passes its self-diagnostic procedure, the control enters into the idle mode.

*Thermostat calls for heat.*

- A) Safety check is made for flame (4 second delay).
  - 1) If flame is not present, the oil primary control will apply power to the burner motor and igniter.
  - 2) If flame is present, the control remains in the idle state.
  
- B) Unit enters a pre-purge period of 15 seconds.
  
- C) After 10 seconds, control checks for flame presence.
  - 1) If flame is not present, the oil primary control enters the trial for ignition state.
  - 2) When flame is present, the control enters lock out mode.
  
- D) Control monitors the burner flame.
  - 1) When flame is present, the control enters ignition carryover state. (Continues to spark for 10 sec.).
    - a) Provides continuous spark after flame is sensed to assure that burner remains lit.
    - b) Turns on LED diagnostic light.
    - c) Starts carryover timer.
      - (i) Flame and call for heat are monitored.
        - If flame is lost and lockout timer has not expired, the control will return to trial for ignition state.
        - If flame is lost and lockout timer has expired, the control will enter the recycle state.
          - ◆ Recycle timer starts.
          - ◆ Burner motor and igniter and solenoid valve are turned off.
          - ◆ LED diagnostic light flashes slowly.
  
- E) Carryover timer expires.
  - 1) Enters run state.
    - a) Igniter turns off.

*Combustion continues until thermostat is satisfied, or oil primary control detects a loss of flame and enters into Recycle Mode.*

- F) Thermostat is satisfied - call for heat is terminated:
  - a) Oil primary control shuts off burner motor and solenoid valve.
    - (i) If control utilizes a blower motor off delay, after 30 seconds, flame presence is checked.
      - If flame is not present, the control LED diagnostic light is off and returns to idle state.
      - If flame is presence is detected, the control enters lock out mode.

**FIGURE 7: UNITED TECHNOLOGIES 1158-120 FAN TIMER BOARD**

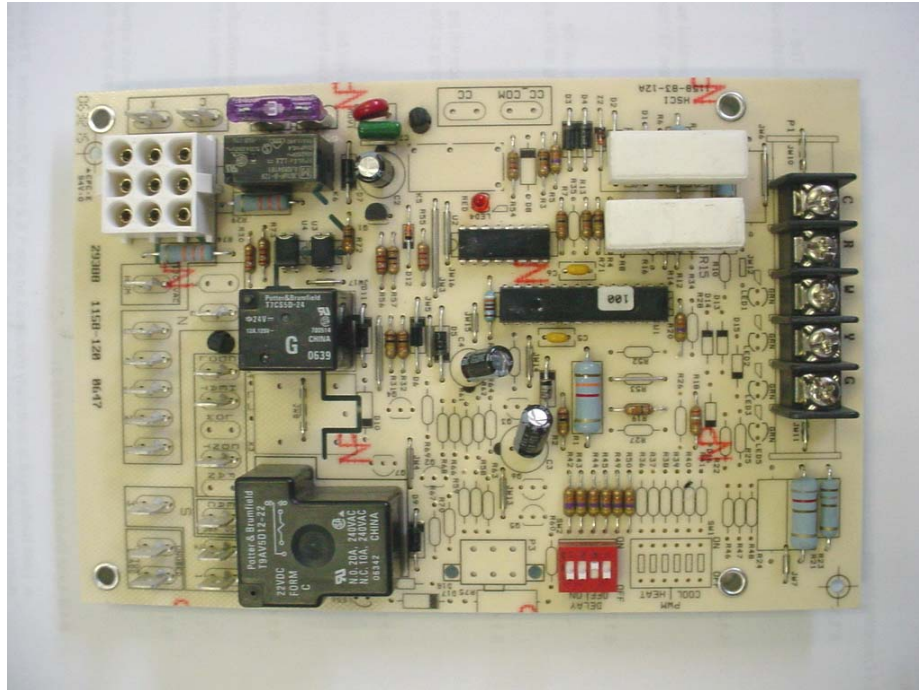

**FIGURE 8: UNITED TECHNOLOGIES 1168-1 ECM TAP BOARD**

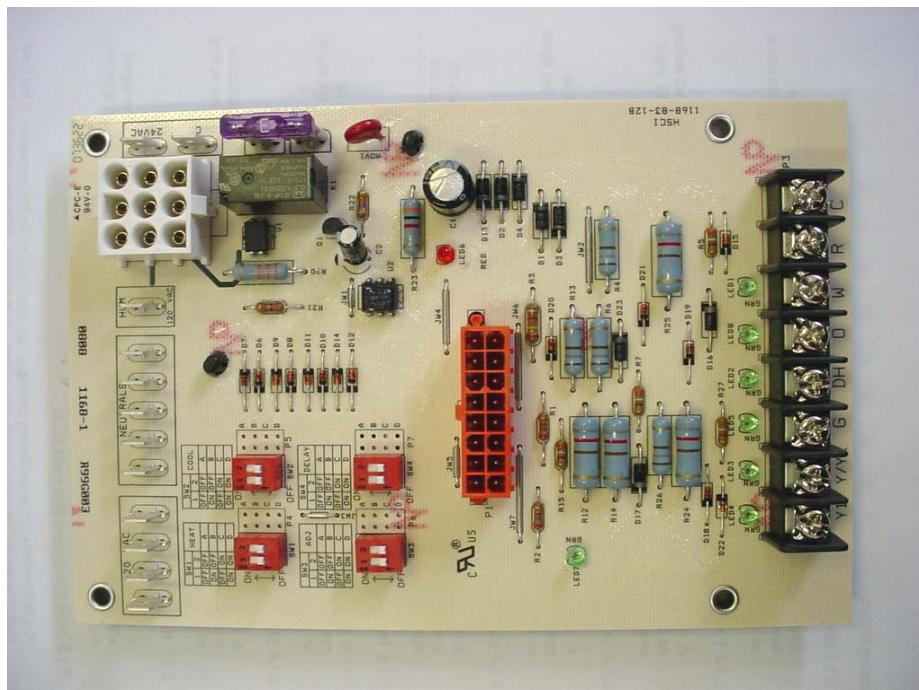

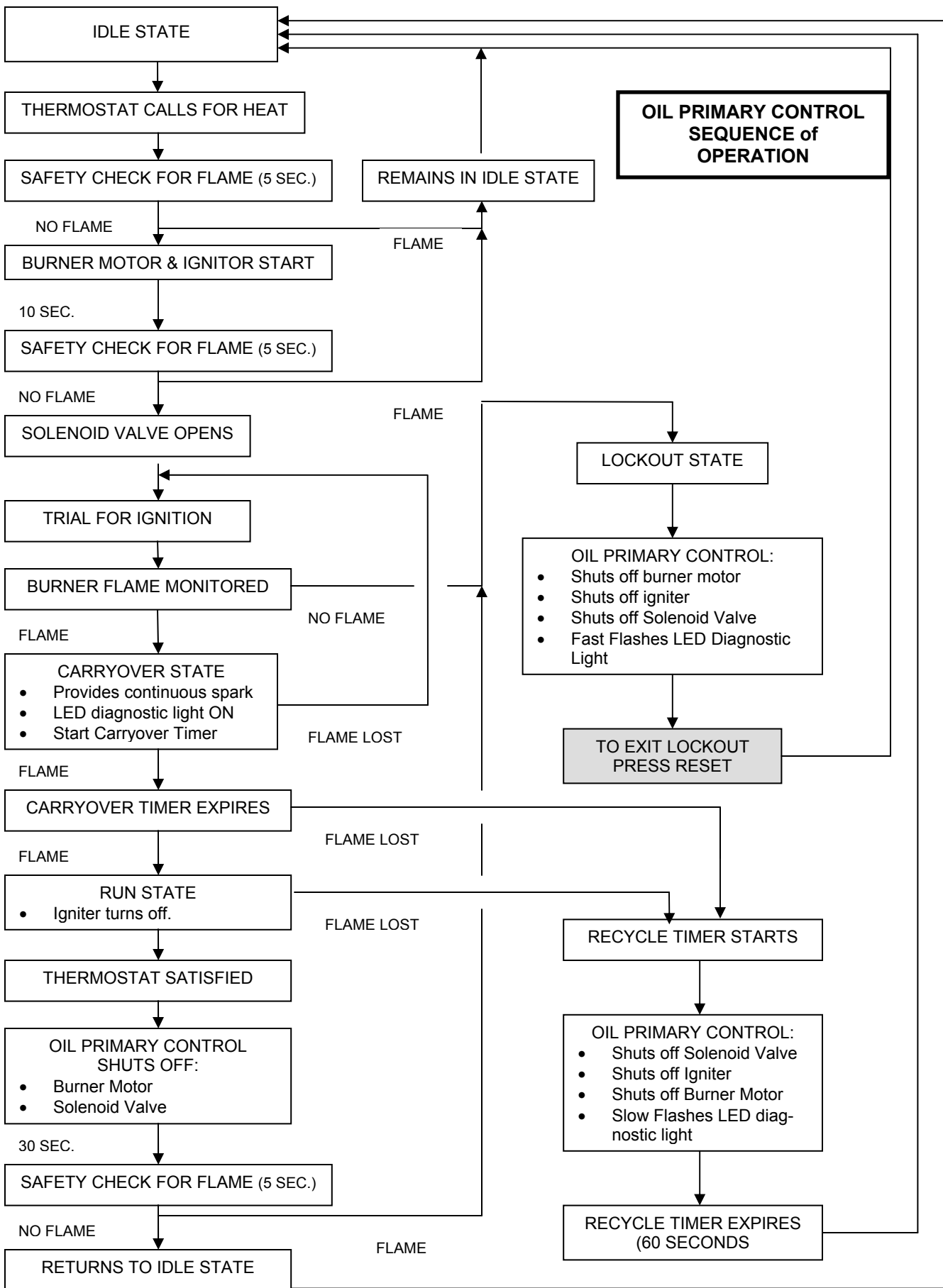



**Table C-1: 1158-120 ELECTRONIC FAN TIMER BOARD (EFT) DETAILED SEQUENCE OF OPERATION**

Mode	Action	System Response
HEAT	Thermostat calls for heat. ("W" terminal is energized).	<ol style="list-style-type: none"> <li>EFT closes oil primary control T - T connections).</li> <li>Ignition system and the oil primary control start the furnace. Oil flows as long as the oil primary control senses flame.</li> <li>Burner motor is energized and heat "fan on" delay timing begins. When timing is complete, the circulator fan is energized at heat speed.</li> </ol>
	Thermostat ends call for heat. ("W" terminal is de-energized).	<ol style="list-style-type: none"> <li>The oil primary control is de-energized, terminating the burner cycle.</li> <li>Heat "fan off" delay timing begins. Length of delay depends on EFT dipswitch settings. When timing is complete, the circulator fan is de-energized.</li> <li>EFT returns to standby mode, (Oil primary control and circulator fan are off, unless continuous fan operation is selected at the thermostat).</li> </ol>
	Burner fails to light.	<ol style="list-style-type: none"> <li>Oil primary control locks out within lockout timing, (30 seconds).</li> <li>Burner motor is de-energized. (Even though thermostat is still calling for heat).</li> <li>If circulator fan has started, it continues through the selected heat "fan off" delay period.</li> </ol>
	Established flame fails.	<ol style="list-style-type: none"> <li>Burner motor is de-energized and oil primary control goes into recycle mode.</li> <li>If the selected heat "fan off" delay timing is longer than the recycle delay timing, the circulator fan continues to run through the next trial for ignition.</li> </ol>
COOL	Thermostat begins call for cool. (G and Y terminals are energized).	<ol style="list-style-type: none"> <li>Cooling contactor is energized immediately.</li> <li>Circulator fan is energized at cool speed.</li> </ol>
	Thermostat ends call for cool. (G and Y terminals are de-energized).	<ol style="list-style-type: none"> <li>Cooling contactor is de-energized immediately.</li> <li>Circulator fan turns off immediately.</li> </ol>
FAN	Thermostat begins call for fan. (G terminal is energized).	<ol style="list-style-type: none"> <li>Circulator fan is energized immediately at cooling speed.</li> </ol>
	Thermostat ends call for fan. (G terminal is de-energized).	<ol style="list-style-type: none"> <li>Circulator fan is de-energized immediately.</li> </ol>
LIMIT	Limit switch string opens.	<ol style="list-style-type: none"> <li>Oil primary control shuts off burner.</li> <li>Circulator fan is energized immediately at heat speed.</li> <li>EFT opens oil primary control T - T connections. Circulating fan runs as long as limit string stays open.</li> <li>If there is a call for cooling or fan, the circulating fan switches from heating to cooling speed.</li> </ol>
	Limit switch string closes (with existing call for heat).	<ol style="list-style-type: none"> <li>EFT begins heat "fan off" delay sequence.</li> <li>Circulating fan turns off after the selected heat "fan off" timing.</li> <li>EFT re-closes oil primary control T - T connections.</li> <li>Oil primary control is energized, initiating burner light off.</li> </ol>
	Limit switch string closes (without existing call for heat).	<ol style="list-style-type: none"> <li>Circulator fan turns off when heat "fan off" delay time is complete.</li> <li>Normal operation resumes; EFT control is in standby mode awaiting next thermostat command.</li> </ol>
FAN	Continuous circulating fan is connected.	<ol style="list-style-type: none"> <li>Circulating fan is energized when there is no call for heat, cool, or fan.</li> <li>If fan operation is required by a call for heat, cool, or fan, the EFT switches off the continuous fan speed tap before energizing the other fan speed.</li> </ol>
EAC	Electronic Air Cleaner is connected.	<ul style="list-style-type: none"> <li>Electronic air cleaner (EAC) connections are energized when the heat or cool speed of the circulator fan is energized. EAC connections are not energized when the optional continuous fan terminal is energized.</li> </ul>
HUM	Humidity control is connected.	<ul style="list-style-type: none"> <li>Humidifier connections are energized when the oil burner motor is energized.</li> </ul>

## 1168-1 ELECTRONIC FAN TIMER BOARD (EFT) DETAILED SEQUENCE OF OPERATION

### Thermostat Input LED's (LED1-5, LED8)

Six green LED's are placed behind their respective thermostat connections (Y1, Y1/Y2, G, DH, O, and W) and operate whenever a call is present.

**Thermostat calls for "W".** The 24VAC input signal is passed to pin 2 of P1 and will drive the K1 relay that provides dedicated contacts to the T-T input of the Oil Primary Control. **Thermostat calls for cool "Y1".** The 24VAC input signal is passed to pin 6 of P1. **Thermostat calls for fan "G".** The 24VAC input signal is passed to pin 15 of P1. **Thermostat calls for dehumidification "DH".** The 24VAC input signal is passed to pin 10 of P1. **Thermostat calls for reversing valve "O".** The 24VAC input signal is passed to pin 9 of P1.

### OIL PRIMARY CONTROL LED DIAGNOSTIC LIGHT

The LED diagnostic light has several functions. It indicates the state or mode in which the oil burner is operating. It will also indicate fault conditions, and help determine cad cell resistance while the burner is operating.

#### NORMAL CONDITIONS:

The LED diagnostic light will turn on when the burner enters the carryover state; the point at which ignition spark is on, and will remain on through the run state, where the ignition spark is terminated but the burner continues to fire.

The LED diagnostic light will turn off at the end of the burner cycle as the oil primary control enters the idle state, and will remain off until the next heating cycle.

#### FAULT CONDITIONS:

If the LED diagnostic light is flashing quickly; 1 Hz (½ second on / ½ second off), the oil primary control is in the lockout state or in restricted mode. To exit the lockout state, press the reset button.

If the LED diagnostic light is flashing slowly; ¼ Hz (2 seconds on / 2 seconds off), the oil primary control is in the recycle state. This indicates that flame sensing was lost after the lockout timer expired during the ignition carryover state. The oil primary control will return to the idle state within 60 seconds.

### CAD CELL CONDITION:

If the LED diagnostic light is off, the cad cell is not sensing flame.

If the LED diagnostic light is on, the cad cell is sensing flame, or viewing ambient light.

The resistance of the cad cell may be checked while the oil primary control is in the run state by pressing the reset button. The LED diagnostic light will flash the following code:

**TABLE C-2: CAD CELL RESISTANCE**

Flashes	Resistance in Ohms
1	Less than 400
2	Between 400 - 800
3	Between 800 - 1600
4	Between 1600- 5000

### TROUBLESHOOTING

**IMPORTANT:** Due to the potential hazard of line voltage, only a trained, experienced service technician should perform the troubleshooting procedure.

#### PRELIMINARY STEPS:

Check the diagnostic light for indications of burner condition. Refer to the oil primary control LED DIAGNOSTIC LIGHT section for details.

### CAUTION

**WHEN SIMULATING A CALL FOR HEAT AT THE OIL PRIMARY CONTROL, DISCONNECT AT LEAST ONE THERMOSTAT LEAD WIRE FROM THE T1 - T2 TERMINALS TO PREVENT DAMAGE TO THE THERMOSTAT. NEGLECTING THIS PROCEDURE MAY BURN OUT THE HEAT ANTICIPATOR OF A STANDARD 24 VAC THERMOSTAT, OR CAUSE HARM TO COMPONENTS WITHIN A MICRO-ELECTRONIC THERMOSTAT.**

Before checking the oil primary control, perform these preliminary checks, (repair or replace controls as necessary):

- Check the power supply; fuse box or breaker, any service switches, all wiring connections, and burner motor reset button (if equipped).

- Check the limit switches to ensure that the switch contacts are closed.
- Check the electrode gap and position.
- Check the contacts between the oil primary control and the electrodes.
- Check oil supply (tank gauge).
- Check the oil nozzle, oil filter, and oil valves.
- Check the piping or tubing to the oil tank.
- Check the oil pump pressure.

### CHECK OIL PRIMARY CONTROL AND IGNITER

If the trouble does not appear to be in the burner or ignition hardware, check the oil primary control and the igniter by using the following equipment:

Screwdriver.

Voltmeter (0 - 150 VAC)

Insulated jumper wires with both ends stripped.

### WARNING

#### Electrical Shock Hazard.

Troubleshooting is done with the system powered. Be careful to observe all necessary precautions to prevent electrical shock or equipment damage.

#### PRELIMINARY CHECKS:

Make sure that limit switches are closed and those contacts are clean.

Check for line voltage power on the oil primary control black and white lead wires.

Refer to Table C-4 or C-5 for further troubleshooting information.

**Table C-3: OIL PRIMARY CONTROL TROUBLESHOOTING**

**Condition: Burner motor does not start when there is a call for heat.**

Procedure	Status	Corrective Action
1. Check that limit switches are closed and contacts are clean.	N/A	N/A
2. Check for line voltage power at the oil primary control. Voltage should be 120 Vac between the black and white lead wires on the oil primary control.	N/A	N/A
3. Check indicator light with burner off, no call for heat (no flame).	Indicator light is on.	Cad cell is defective, sees external light, or connections have shorted. Go to step 4.
4. Shield cad cell from external light.	Indicator light turns off.	Eliminate external light source or permanently shield cad cell.
	Indicator light stays on.	<ul style="list-style-type: none"> <li>• Replace cad cell with new cad cell and recheck.</li> <li>• If indicator light does not turn off, remove yellow lead wires from the oil primary control and recheck.</li> <li>• If indicator light is still on, replace the oil primary control.</li> <li>• If the indicator light turns off, replace cad cell bracket assembly.</li> </ul>
5. Verify that the oil valve is closed during the "valve on delay" period by opening view port and verifying that no flame is present during the 15-second "valve on delay".	Indicator light is on.	If flame is present, replace the oil valve.
<b>IMPORTANT</b> First remove one thermostat lead wire.	Burner starts.	Trouble is in thermostat circuit. Check thermostat-wiring connections. If connections are clean and tight, check thermostat wires for continuity.
	Burner does not start.	<ul style="list-style-type: none"> <li>• Disconnect line voltage power and open line switch.</li> <li>• Check all wiring connections.</li> <li>• Tighten any loose connections and recheck.</li> <li>• If burner still doesn't start, replace oil primary control.</li> </ul>
		If burner still doesn't start, check the oil burner motor. It may be seized or burned out.

**Condition: Burner starts then locks out on safety with indicator light flashing at 1/2 second on, 1/2 second off.**

Procedure	Status	Corrective Action
7. Reset oil primary control by pushing in and releasing red reset button.	Indicator light stops flashing.	Go to Step 8.
	Indicator light continues to flash at 1/2 second on, 1/2 second off rate.	Verify that the control is not in restricted mode. (See notes at end of this table.). If not in restricted mode, replace oil primary control

<b>Condition: Burner starts then locks out on safety with indicator light flashing at 1/2 second on, 1/2 second off. (Cont.)</b>		
<b>Procedure</b>	<b>Status</b>	<b>Corrective Action</b>
8. Listen for spark after burner turns on (after 2 second delay).	Ignition is off	Spark igniter could be defective. Check for line voltage at igniter terminals. If line voltage is present, replace oil primary control.
	Ignition is on.	Go to Step 9.
	Ignition is on but no oil is being sprayed into the combustion chamber.	Wait for "Valve ON" delay to complete. Check oil supply, and oil line valve. Check for filter blockage or seized oil pump.
9. Check indicator light after flame is established, but before oil primary control locks out.	Indicator light is on until the control locks out and starts flashing during lockout.	Replace oil primary control
	Indicator light stays off.	Go to step 10.
10. Check cad cell sighting for view of flame. a. Disconnect line voltage power and open line switch. b. Unplug cad cell and clean cad cell face with soft clothe. Check sighting for clear view of flame. Replace cad cell in socket. c. Reconnect line voltage power and close line switch. d. Start burner.	Burner locks out.	Go to step 11.
	Burner keeps running.	System is OK.
11. Check cad cell. a. Disconnect line voltage power and open line switch. b. Remove existing cad cell and replace with new cad cell. c. Disconnect all wires from thermostat terminals to ensure that there is no call for heat. d. Reconnect line voltage power and close line switch. e. Expose new cad cell to bright light such as a flashlight.	Indicator light is on.	Remount control onto burner housing. Go to step 6.
	Indicator light is off.	Go to step 12.
12. Check cad cell bracket assembly. a. Disconnect line voltage power and open line switch. b. Remove cad cell wires from quick connect connectors on the oil primary control and leave control lead wires open. c. Apply power to device. d. Place jumper across cad cell terminals after burner motor turns on.	Indicator light is on.	Replace cad cell bracket assembly.
	Indicator light is off.	Replace oil primary control.
NOTE: Restricted Mode - (Limited Reset): In order to limit the accumulation of unburned oil in the combustion chamber, the control can be reset only 3 times, after which, the control locks out. The reset count returns to zero each time a call for heat is successfully completed. To reset from RESTRICTED MODE: press and hold the reset button for 30 seconds. When the LED flashes twice, the device has reset.		
NOTE: Disable function: Pressing and holding the reset button will disable all functions until the button is released. The burner will restart at the beginning of the normal heat cycle on SAFETY CHECK.		

**TABLE C4: SYSTEM AND GENERAL TROUBLESHOOTING**

<b>Problem</b>	<b>Possible Cause</b>	<b>Remedy</b>
Furnace will not start.	Thermostat not calling for heat.	Check thermostat and adjust. Also, check thermostat for accuracy; if it is a mercury switch type, it might be off level.
	No power to furnace.	Check furnace switch, main electrical panel furnace fuse or circuit breaker. Also look for any other hand operated switch, such as an old poorly located furnace switch, which was not removed during furnace replacement.
	Thermostat faulty.	Remove thermostat wires from oil primary control terminals T-T. Place a jumper across T-T. If furnace starts, replace thermostat, thermostat sub-base (if equipped), or both.
	Oil primary control faulty.	Check reset button on oil primary control. Remove thermostat wires from oil primary control terminals T1 - T2. Check for 24V across T -T. If no voltage is present, check for 115V to oil primary control. If 115V is present, go to Table C-3.
Furnace will not start.	Photo Cell wiring shorted or room light leaking into photo cell compartment	Check photo cell (cad cell) wiring for short circuits. Also, check for room light leaking into cad cell compartment. Repair light leak if necessary. See Table C-3.
	Open safety switch.	Check for open limit or auxiliary limit. Also, check internal wiring connections; loose connectors, etc.
Furnace will not start without first pushing oil primary control reset button. (Happens on frequent basis)	No fuel oil.	Check fuel oil supply. Check that all hand operated fuel oil valves are in the open position. Fill oil storage tank if necessary.
	Clogged nozzle.	Replace nozzle with high quality replacement. Use rating plate or Tables in Appendix A as a guide.
	Clogged oil filter.	Replace oil tank filter or in-line filter if used.
	Low oil pump pressure.	Connect pressure gauge to oil pump. Adjust pump pressure, or replace oil pump if necessary. Ensure that erratic pressure readings are not caused by defective fuel oil line.
	Air getting into fuel oil lines, or fuel oil line dirty, clogged, or in some manner defective.	Check fuel oil lines. Replace any compression fittings found with high quality flared fittings. Check for any signs of oil leaks. Any oil leak is a potential source of air or contaminants.
	Defective burner motor.	Check burner motor. If burner motor is cutting out on over-load, determine why. Replace if necessary.
Furnace starts, but cuts out requiring manually resetting the oil protector reset button.	Photo Cell (Cad Cell) defective.	If cad cell is dirty, clean it. (Determine why cad cell is getting dirty). If cad cell is poorly aimed, realign it. NOTE: The photocell should have a resistance of 100K $\Omega$ in absence of light; a maximum of 1500 $\Omega$ in the presence of light. Ensure that room light is not leaking into the cad cell compartment. (See diagnostic light section).
Furnace starts, but cuts out requiring manually resetting the oil protector reset button.	No fuel oil.	Check fuel oil supply. Check that all hand operated fuel oil valves are in the open position. Fill oil storage tank if necessary.
	Clogged nozzle.	Replace nozzle with high quality replacement. Use rating plate or Tables in Appendix A as a guide.
	Clogged oil filter.	Replace oil tank filter or in-line filter if used.
	Low oil pump pressure.	Connect pressure gauge to oil pump. Adjust pump pressure, or replace oil pump if necessary. Ensure that erratic pressure readings are not caused by defective fuel oil line.
	Air getting into fuel oil lines, or fuel oil line dirty, clogged, or in some manner defective.	Check fuel oil lines. Replace any compression fittings found with high quality flared fittings. Check for any signs of oil leaks. Any oil leak is a potential source of air or contaminants.
	Defective burner motor.	Check burner motor. If burner motor is cutting out on over-load, determine why. Replace if necessary.
	Water or contaminants in oil.	Drain fuel oil storage tank, replace fuel oil. (Consult with fuel oil supplier).
	Frozen oil line.	Gently warm oil line. Insulate oil line. (Outdoor piping size may require increased diameter).

**TABLE C-4: SYSTEM AND GENERAL TROUBLESHOOTING** *continued*

<b>Problem</b>	<b>Possible Cause</b>	<b>Remedy</b>
Oil burner sputtering at nozzle	Electrodes out of adjustment or defective.	Check electrode settings. Check electrodes for dirt build-up or cracks in porcelain.
	Poor transformer high voltage connections or defective transformer.	Check contacts between the igniter and electrodes. If OK, replace the igniter
	Fuel oil filter clogged.	Replace fuel oil storage tank filter and / or fuel oil in-line filter.
	Defective oil pump.	Check burner motor / fuel oil pump coupling. Check oil pump pressure. Replace fuel oil pump if necessary.
	Fuel oil line partially clogged or contains air.	Bleed air from oil line. If problem persists, replace oil line.
Excessive fuel oil consumption.	System temperature rise too high.	System temperature rise ideally should not exceed 85°F. Check for clogged air filters. Check blower fan for excess dirt build-up or debris. Speed up blower fan if necessary.
	Poor "fan off" delay timing selection, (fan stops too soon).	Check "fan off" delay timing setting. Use a duct thermometer in the supply air plenum take-off or first few inches of the supply air trunk duct. Ideally, the fan will shut off at a temperature of 90° - 100°F. Manipulate the dip switch settings to come as close as possible to this "fan off" temperature.
	Fuel oil leak.	Check fuel oil line for leaks. Repair or replace if necessary.
	Stack temperature too high.	Check stack temperature. Stack temperatures will normally range from 350° to 450°F. Check draft regulator. Draft should be set to -0.02 in. w.c.
	Thermostat improperly adjusted or in poor location.	Check thermostat heat anticipator setting against measured amperage draw. Increase heat anticipator setting if necessary. If the thermostat is being influenced by drafts, sunlight, duct work, etc., relocate to more suitable location.
Too much smoke.	Insufficient combustion air adjustment at oil burner, or improper draft pressure.	Adjust the oil burner combustion air band and draft regulator to gain the highest practical CO <sub>2</sub> or lowest practical O <sub>2</sub> content in the flue gases. See Burner Set Up.
	Heat exchanger partially clogged.	Check for soot build-up in heat exchanger flue passages, especially in the outer radiator.
Soot building up on blast tube (end coning).	Poor alignment between oil burner blast tube and fire pot.	Check alignment. Blast tube should be centered with fire pot burner opening. Oil burner head should be ¼ inch back from the inside surface of the fire pot.
	Flame impingement caused by incorrect nozzle angle.	Check nozzle size and angle. (See Appendix A). Check distance from head to inside surface of the fire pot.
	Defective fire-pot	Check fire-pot. Repair or replace.
Furnace will not warm home to desired temperature.	Airflow blocked or dirty air filter.	Clean or replace air filter.
	Thermostat adjustments or location.	Check thermostat heat anticipator setting against measured amperage draw. Increase heat anticipator setting if necessary. If the thermostat is being influenced by drafts, sunlight, duct work, etc., relocate to more suitable location.
	Insufficient airflow.	Check all dampers. Open closed dampers including registers in unused rooms. Check system temperature rise. If temperature rise is too high, speed up blower fan.
	Defective high limit control.	Test high limit function of all limit switches. Use a duct thermometer to assess accuracy of limit control. Check for obstructions to airflow around limit switch bi-metal elements. Replace control if necessary.
	Under-sized nozzle.	Check nozzle. If problem is not caused by air flow problems, use larger nozzle, if permitted by rating plate.
	Blower fan motor stopping intermittently on overload.	Check blower fan motor amperage draw. Check motor ventilation ports, clean if necessary. Replace motor if necessary.
	Burner motor stopping intermittently on overload.	Check burner motor. Replace if necessary.
Home does not heat evenly	Improper distribution of heat.	This is not likely to be a furnace problem. Balance duct system.

**TABLE C-4: SYSTEM AND GENERAL TROUBLESHOOTING** *continued*

Problem	Possible Cause	Remedy
Supply air temperature too hot.	Airflow blocked or dirty air filter.	Clean or replace air filter.
	Insufficient airflow.	Check all dampers. Open closed dampers including registers in unused rooms. Check system temperature rise. If temperature rise is too high, speed up blower fan.
Supply air temperature too cool.	Excess airflow.	Check system temperature rise. Slow down blower fan if necessary.
	Excessive duct losses.	Check supply air ductwork. Seal leaky joints and seams. Insulate ductwork if necessary.
Supply air temperature too cool during first moments of furnace cycle.	Fan control "fan on" setting too low.	Increase "fan on" dipswitch settings on EFT if control has this option.). Register air deflectors may help.
	Excessive duct losses.	Check supply air ductwork. Seal leaky joints and seams. Insulate ductwork if necessary.

**FINAL CHECK OUT**

**ENSURE THAT ALL SAFETY DEVICES AND ELECTRICAL COMPONENTS HAVE BEEN SET FOR NORMAL OPERATION. ENSURE THAT ALL ELECTRICAL CONNECTIONS ARE TIGHT AND THAT THE WIRING IS SECURE.**



**IMPORTANT:**

Please ensure that the homeowner is informed and understands:

Where the circuit breaker or fuse is located in the main electrical panel.

Where the furnace switch is located, and the switch "on" and "off" positions if not obvious.

Where the oil shut-off valve from the oil storage tank is located.

How to operate the thermostat, and other related accessories.

How to operate the manual reset button on the primary control, and especially when not to push the reset button.

How and where to visually inspect the venting system for leaks or other problems.

How to inspect, clean and replace the air filter, and other homeowner maintenance procedures.

Who to call for emergency service and routine annual service.

The terms and conditions of the manufacturer's warranty and the contractor's warranty.

**PARTS LISTING: COUNTERFLOW HORIZONTAL MODEL: WML-C and WMLV-C**

Ref. No.	Description	PART NO.
1	Right and Left Side Panel	30072L
2	Rear Panel Baffle	27918
3	Rear Panel	30272L
4	Blower Division Panel Assembly	30311
5	Base Panel Assembly	29007
6	Front Panel	30073L
7	Blower Access Door	30074L
	Door Handle – P2-41	28673
	Logo Bezel	28479
	Logo Label	28563
8	End Panel	29013L
9	Heat Exchanger Assembly	27876
10	Firepot Retainer Bracket	27068
11	Replacement Combustion Chamber	2700WP
12	Oil Burner Mounting Plate Assembly	29873
13	Flue Pipe Connecting Flange	29005
15	Pouch Gasket	2080175
16	Flue Pipe Gasket (2 per Unit)	21994
17	Radiator Clean-out Cover Assembly	1061A
	Clean-out Cover Gasket	2080176
18	Casing Clean-out Cover	3011325A
19	Filter Frame	21260
20	Filter Frame End Support	21306
21	Air Filter – 20 x 20 x 1 (Permanent)	2180032
23	Channel Wire Retainer	30239
24	Limit Control 60T11BOF L180° F	28654
25	Wire Harness Control	30268
26	Wire Harness Blower Direct drive	30265
35	Wire Harness ECM Control	240006438
35	Wire Harness ECM Supply	240005742
27	Fan Timer Control: 1158-120 UTEC	29388
27	Fan Timer Control: 1168-1 ECM UTEC	240007048
28	Draft Regulator 5"	27494
29	Beckett oil Burner AF76BNHS	30288
	Burner Motor 1/7 HP 3450 RPM PSC	29689
	Beckett Clean-cut Oil Pump	29688
	Solid State Igniter	29522
	Oil Primary Combustion Control	29664
	Flame Retention Head	11961 (F3)
	Nozzle 0.65 / 80° A	210086
30	Blower Assembly, Complete, Direct Drive, ½ hp, 4-Speed	30313
	Blower Housing and Wheel, 100-10T DD	30626
	Blower Motor, ½ hp, 4-Speed	102000131
	Blower Motor ½ hp ECM Programmed	109007381
	Motor Mounting Band – TR6884B	17811
	Motor Mount Arms – 10-10 DD Blower (3 per unit)	26251
	Motor Run Capacitor, 10 mfd @ 370 Vac	27743
	Capacitor Strap	27760
	Low Fire Kit	29880
	Low Firing Rate Baffle	25521101
	Nozzle, 0.50/80° A	29389



**PARTS LISTING: COUNTERFLOW HORIZONTAL MODEL: WML-C and WMLV-C**

Ref. No.	Description	PART NO.
31	Auxiliary Limit 60T11BOF L140° F	29198
32	Transformer	27738
33	Control Panel	30190
34	Wire Harness, Fan Timer Board to Transformer	29751
36	Limit Cover, Left	30240
37	Limit Cover, Right	30195

**PARTS LISTING: COUNTERFLOW HORIZONTAL DIRECT VENT MODEL: WML-CB2U and WMLV-CB2U**

Ref. No.	Description	PART NO.
All parts are the same as listed on the previous pages for Model WML-C and WMLV-C except where noted below.		
12	Oil Burner Mounting Plate Assembly	29872
	Oil Burner Mounting Plate	29867
	Sight Glass Cover Plate	29850
	Sight Glass Gasket (2 per unit)	29870
	Sight Glass	29876
13	Flue Connector Assembly 6" to 4" 90° Elbow	28952
14	Pouch Gasket (Second gasket required for Direct Vent)	2080175
15	Flue Collar Gasket (Second gasket required for Direct Vent)	21994
34	Beckett Oil Burner AFII 85	30069
	Burner Motor 1/7 HP 3450 RPM PSC	28907
	Beckett Clean-cut Oil Pump A2EA6520	29688
	Solid State Ignitor 10SAY-01	28558
	Oil Primary Combustion Control	29649
	Air Tube Combination FBX80HGXS	28561
	Flame Retention Head (FB3)	28533
	Nozzle, 0.60/60°A (WML-80CB2U only)	28017

**PARTS LISTING: VESTIBULE KIT: WML-C and WMLV-C**

Ref. No.	Description	PART NO.
	Vestibule Kit	30554
	Door Handle	28673
	Base Panel	29019
	Top Panel	21437L
	Door Panel	29022L
	Left Side Panel	30527L
	Right Side Panel	30528L

**PARTS LISTING: SUB BASE FOR COMBUSTIBLE FLOOR INSTALLATION: WML-C and WMLV-C**

Ref. No.	Description	PART NO.
	Sub Base	06000075

**MODEL WML-80C and  
WMLV-80C DIAGRAM**

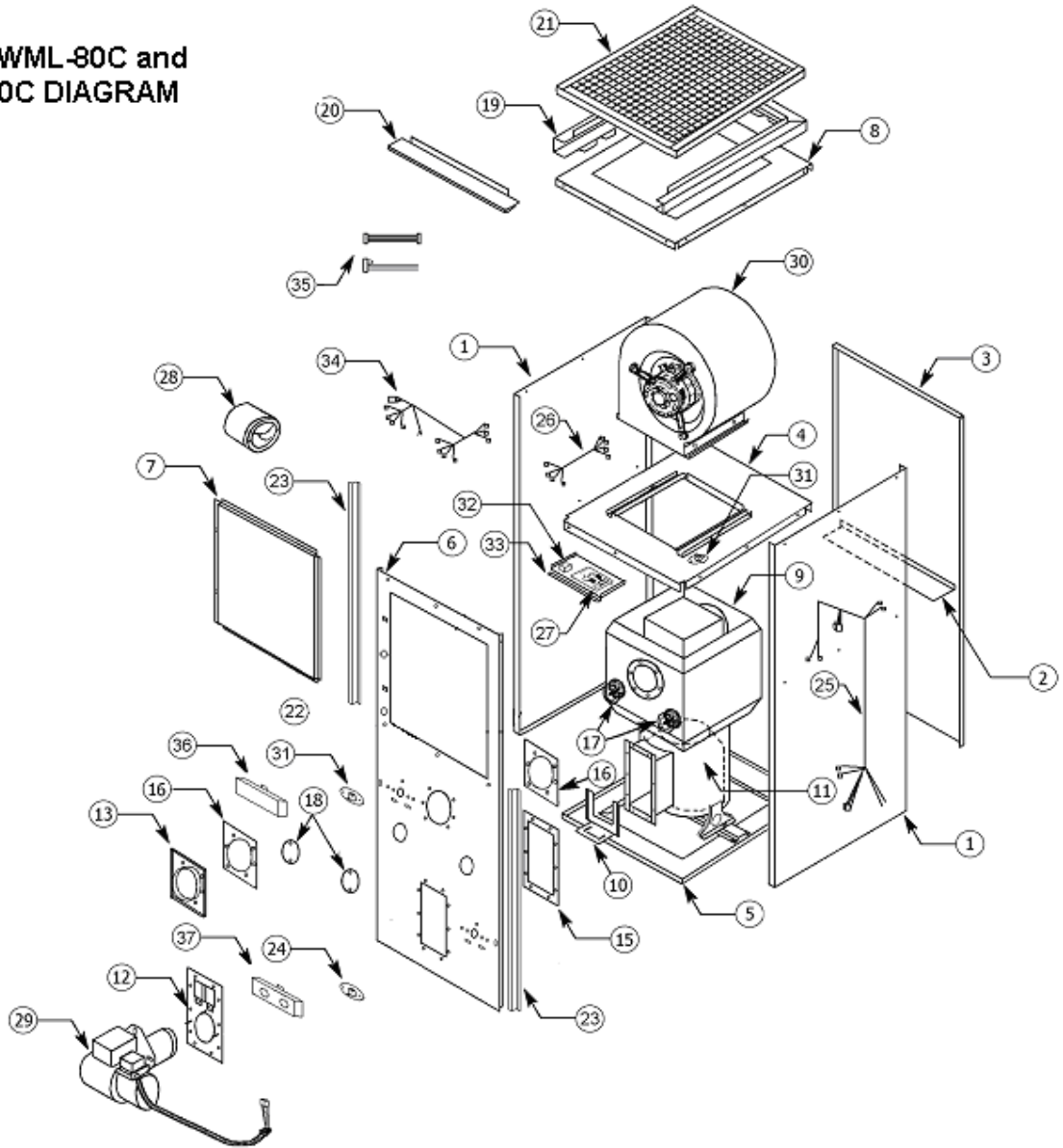

**PARTS LISTING: COUNTERFLOW HORIZONTAL MODEL: MPL-B**

<b>Ref. No.</b>	<b>Description</b>	<b>PART NO.</b>
1a	Right Side Panel	30360L
1b	Left Side Panel	30351L
2	Side Panel Heat Exchanger Support (2 per unit)	27038
3	Rear Panel	30353L
4	Blower Division Panel Assembly	30397
5	Base Heat Exchanger Support	26975
6	Front Panel	30350L
7	Blower Access Door	30363L
	Door Handle – P2-41	28673
	Logo Bezel	28479
	Logo Label	28563
8	End Panel	30352
9	Heat Exchanger Assembly	30380
10	Firepot Retainer Bracket	27068
11	Replacement Combustion Chamber	27000WP
12	Oil Burner Mounting Plate Assembly	29873
	Inspection Door Gasket	29871
13	Flue Connector	28306
14	Pouch Gasket	2080175
15	Flue Pipe Gasket	21994
16	Radiator Cleanout Cover Assembly	1061A
	Cleanout Cover Gasket	2080176
17	Casing Clean-out Cover	3011325A
18	Filter Frame	21260
19	Filter Frame End Support	21306
20	Air Filter – 20 x 20 x 1 (Permanent)	2180032
22	Channel Wire Retainer	30239
23	Limit Control 60T11BOF L150° F	29197
24	Limit Control 60T11BOF L160° F	29662
25	Wire Harness Junction Box to Control	30392
26	Wire Harness Blower Direct drive	30391
27	Fan Timer Control: UTC 1158-120	29388
28	Air Baffle	30364
30	Limit Cover, Left	30240
31	Limit Cover, Right	30195
32	Draft Regulator 6"	12240
33	Transformer	27738
34	Control Panel	30355
35	Wire Harness Burner to Timer Board	30390
36	Wire Harness Transformer to Timer Board	30393

**PARTS LISTING: COUNTERFLOW HORIZONTAL MODEL: MPL-B**

Ref. No.	Description	PART NO.
37	Beckett Oil Burner AF76XN	30389
	Burner Motor 1/7 HP 3450 RPM PSC	29689
	Beckett Clean-cut Oil Pump A2EA6520	29688
	Solid State Ignitor FRANCE 10SAY-04	29522
	Oil Primary Combustion Control	29664
	Air Tube Combination AF76XN	27610
	Flame Retention Head (MPL 80, to 120)	11961 (F3)
	Flame Retention Head (MPL 130)	12646 (F6)
	Nozzle 1.00 / 60° A (MPL 120)	27104
	Nozzle 1.10 / 70° A (MPL 130)	2100101
38	Blower Assembly, Complete, Direct Drive, ¾ hp, 4-Speed	30387
	Blower Housing and Wheel, 120-10 DD	17559
	Blower Motor, 3/4 hp, 4-Speed	102000132
	Motor Mounting Band – TR6884B	17811
	Motor Mount Arms – 12-12 DD Blower (3 per unit)	17812
	Motor Run Capacitor, 20 mfd @ 370 Vac	27745
	Blower Slide Rail	29026
39	Auxillary Limit L130°F 60T11 BOF	30388

**PARTS LISTING: COUNTERFLOW HORIZONTAL DIRECT VENT MODEL: MPL CB2U**

Ref. No.	Description	PART NO.
	All parts are the same as listed on the previous pages for Model MPL-B except where noted below.	
12	Oil Burner Mounting Plate Assembly	29872
	Oil Burner Mounting Plate	29867
	Sight Glass Cover Plate	29850
	Sight Glass Gasket (2 per unit)	29870
	Sight Glass	29876
13	Flue Connector Assembly 6" to 4" 90° Elbow	28952
14	Pouch Gasket (Second gasket required for Direct Vent)	2080175
15	Flue Collar Gasket (Second gasket required for Direct Vent)	21994
37	Beckett Oil Burner AFII 150	30430
	Burner Motor 1/7 HP 3450 RPM PSC	28907
	Beckett Clean-cut Oil Pump A2EA6520	29688
	Solid State Ignitor 10SAY-01	28558
	Oil Primary Combustion Control	29649
	Air Tube Combination FBX80HGXS	28561
	Flame Retention Head (FB3)	28533
	Nozzle, 0.85/70°A (MPL-120BB2U only)	

**PARTS LISTING: SUB BASE FOR COMBUSTIBLE FLOOR INSTALLATION: MPL B**

Ref. No.	Description	PART NO.
	Sub Base	006000073

# MODEL MPL-B DIAGRAM

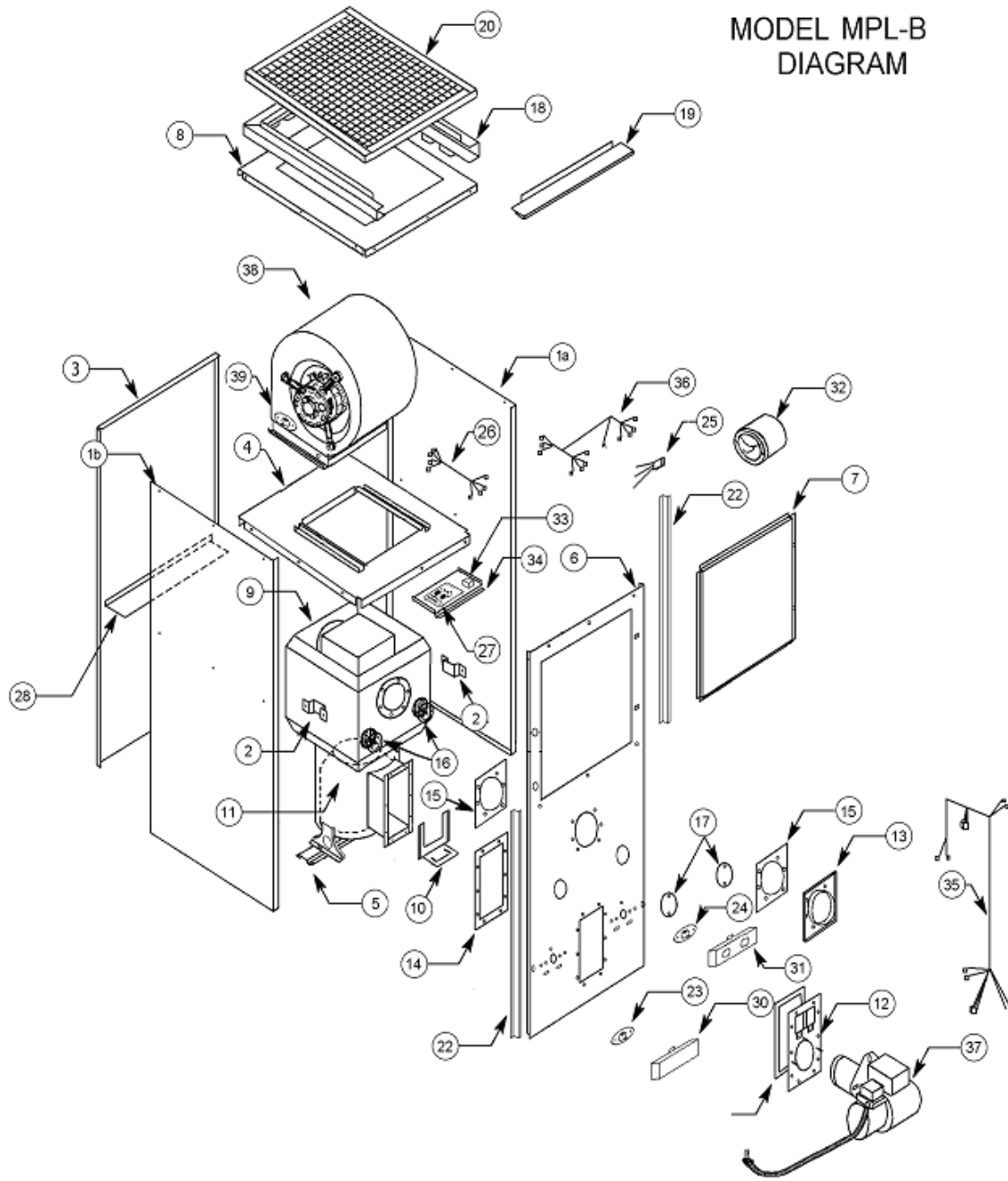

**HOMEOWNER'S REFERENCE TABLE**

Model No.	
Serial No.	
Date Installed	
Contractor	
Contact	
Address	
Postal Code	
Telephone No.	
After Hours No.	

**FUEL SUPPLIER**

Fuel Oil Supplier	
Contact	
Telephone No.	
After Hours No.	

**IF DIFFERENT FROM INSTALLATION CONTRACTOR:**

Service Tech.	
Telephone No.	
After Hours No.	

**NOTES:**



2201 Dwyer Avenue, Utica, New York, 13504, USA. Tel: (315) 797-1310 Fax: (315) 724-9319  
85 Middle Road, Dunkirk, New York, 14048, USA Tel: (716) 366-5500 Fax: (716) 366-1209  
[www.ecrltd.com](http://www.ecrltd.com)